

# Snail Farming in West Africa

Joseph R. Cobbinah



A Practical Guide

# **Agrodok 47**

## **Snail Farming**

Production, processing and marketing

Dr J.R. Cobbinah  
Adri Vink  
Ben Onwuka

# Foreword

There is no reliable documentation on when and where humans started consuming snails as a food supplement. In many places where snails occur, especially in tropical and sub-tropical areas like West and East Africa, natives gather snails, eat them and sell the surplus as a source of income.

This booklet aims to provide ideas to farmers who would like to produce snails on a small scale for consumption or marketing. It is not primarily intended for entrepreneurs wishing to engage in large-scale snail farming for the export market. Attention is focused here on three major species, *Achatina achatina*, *Achatina fulica* and *Archachatina marginata*, that are common in tropical areas, especially in Africa.

Limiting factors to be considered for effective snail farming are discussed so that farmers do not start breeding snails without considering the advantages and constraints.

Incentive for the production of this booklet came from frequent requests for an Agrodok on snail farming received in returned Agrodok questionnaires. A great deal of basic information was provided by Dr Joseph R. Cobbinah's practical guide on *Snail Farming in West Africa*. This was supplemented by literature and internet research, as well as through contacts with African experts on the subject.

Agromisa, August 2008

# Contents

<b>1</b>	<b>Introduction</b>	<b>6</b>
<b>2</b>	<b>Suitable species</b>	<b>10</b>
2.1	Biology of snails	10
2.2	Suitable tropical snail species for farming	12
2.3	<i>Achatina achatina</i>	14
2.4	<i>Achatina fulica</i>	16
2.5	<i>Archachatina marginata</i>	19
2.6	Climatic and environmental requirements and restrictions for raising snails	21
2.7	Cultural and religious restrictions on handling and eating snails	22
<b>3</b>	<b>Choosing a site</b>	<b>23</b>
3.1	General considerations	23
3.2	Temperature and humidity	23
3.3	Wind speed and direction	24
3.4	Soil characteristics	25
<b>4</b>	<b>Constructing a snailery</b>	<b>27</b>
4.1	Choosing a system: the options	27
4.2	Car tyres, oil drums	28
4.3	Hutch boxes	29
4.4	Trench pens	30
4.5	Mini-paddock pens	33
4.6	Free-range pens	35
<b>5</b>	<b>Food and feeding</b>	<b>39</b>
5.1	Introduction	39
5.2	Types of snail food	39
5.3	Recommendations on natural feed	41
5.4	Recommendations on formulated feed	43
5.5	Feeding and growth	45

<b>6</b>	<b>Breeding and management</b>	<b>47</b>
6.1	Selecting breeding stock	47
6.2	Nursery	48
6.3	Rearing density	50
6.4	Seasonal and daily management	50
6.5	Snail farming tools and equipment	53
<b>7</b>	<b>Predators, parasites and diseases</b>	<b>54</b>
7.1	Predators	54
7.2	Parasites	56
7.3	Diseases	57
<b>8</b>	<b>Processing and consumption of snail meat</b>	<b>58</b>
8.1	Processing	58
8.2	Consumption	60
<b>9</b>	<b>Markets</b>	<b>63</b>
9.1	Local markets	63
9.2	Export markets	66
	<b>Appendix 1: Planning a snail farming venture - 5 steps</b>	<b>68</b>
	<b>Appendix 2: Costs of constructing snaileries</b>	<b>71</b>
	<b>Further reading</b>	<b>74</b>
	<b>Useful addresses</b>	<b>76</b>
	<b>Glossary</b>	<b>77</b>

# 1 Introduction

Snail meat has been consumed by humans worldwide since prehistoric times. It is high in protein (12-16%) and iron (45-50 mg/kg), low in fat, and contains almost all the amino acids needed by humans. A recent study has also shown that the glandular substances in edible snail meat cause agglutination of certain bacteria, which could be of value in fighting a variety of ailments, including whooping cough.

Edible snails also play an important role in folk medicine. In Ghana, the bluish liquid obtained from the shell when the meat has been removed is believed to be good for infant development. The high iron content of the meat is considered important in treating anaemia. In the past, it was recommended for combating ulcers and asthma. At the Imperial Court in Rome, snail meat was thought to contain aphrodisiac properties and was often served to visiting dignitaries in the late evening.

In West Africa, snail meat has traditionally been a major ingredient in the diet of people living in the high forest belt (the forested area other than the savannah forest). In Côte d'Ivoire, for example, an estimated 7.9 million kg are eaten annually. In Ghana it is clear that demand currently outstrips supply.

International trade in snails is flourishing in Europe and North America. However, in spite of the considerable foreign and local demand, commercial snail farms such as those in Europe, South-East Asia and the Americas hardly exist in Africa. In Ghana, Nigeria and Côte d'Ivoire, where snail meat is particularly popular, snails are gathered from the forest during the wet season. In recent years, however, wild snail populations have declined considerably, primarily because of the impact of such human activities as deforestation, pesticide use, slash-and-burn agriculture, spontaneous bush fires, and the collection of immature snails. It is therefore important to encourage snail farming (heliculture) in order to conserve this important resource.

## **Advantages of snail farming**

### *Environment*

Snails are environment-friendly, because, unlike poultry or pigs, neither the snail nor its droppings smell offensively. Snails can also be reared in the backyard.

### *Inputs*

Capital, technical, labour and financial inputs in simple snail farming are relatively low compared to those in other types of livestock farming (poultry, pigs, goats, sheep, cattle).

### *Snail meat*

Snail meat is a good source of protein. It is rich in iron and calcium, but low in fat and cholesterol compared to other protein sources like poultry and pigs.

## **Disadvantages of snail farming**

### *Climate*

Without expensive artificial means of climate control, snail farming is restricted to the humid tropical forest zone, which offers a constant temperature, high relative humidity, preferably no dry season, and a fairly constant day/night rhythm throughout the year.

### *Cultural restrictions*

Snail meat is considered a delicacy by some, whereas others will not even touch it for religious or cultural reasons.

### *Growth*

Snails are relatively slow-growing animals. Furthermore the consumable meat makes up only 40% (maximum!) of the snail's total live weight. Consequently snail farming is not a way to make money quickly!

### *Snails as a pest*

Snails that have escaped from a farm, or been dumped by a farmer, may quickly develop into a serious pest in agriculture and horticulture.

For these reasons it must be emphasised that snail farming should be seen as only one component in a diversified farming venture. However, with patience, good management and careful integration into existing farming activities, snail farming can provide substantial longer-term rewards.

### **Planning a snail farming venture**

Agromisa's AgroBrief No. 3, *Snail Farming* (M. Leeflang, 2005) provides useful guidelines for anyone considering snail farming (see also Appendix 1).

A sequence of five steps is suggested:

- 1 Plan (market, production, organisation)
- 2 Pilot production and sales
- 3 Go or no-go decision
- 4 Investment in facilities and know-how (cages/pens, finance, knowledge)
- 5 Upscaling (logistics, quality, financial control)

### **Prescriptions**

The following chapters present prescriptions for the actual farming of snails, e.g. suitable snail species, environment, housing, stock, feed and health.

**Caution:** Before embarking on snail farming make sure you have a market! This may seem self evident; but there are many examples of cases in which giant African land snails (GALS) were introduced to other parts of the world for farming, but were eventually dumped (or allowed to escape) into the wild for lack of a market.

Once the snails have been introduced, dumped or allowed to escape, they develop into a serious agricultural pest. Without any natural ene-



mies they end up destroying a wide range of agricultural and/or horticultural crops and causing considerable economic damage. *Achatina fulica* has a particularly poor reputation in this respect.

Giant African snails are considered a delicacy by people accustomed to consuming them, whereas other people, even within the same country, will not even touch, let alone eat them. For that reason, **don't start farming snails unless you are absolutely sure someone will buy or eat them.**

## 2 Suitable species

### 2.1 Biology of snails

Snails belong to a group of invertebrate animals known as molluscs. Most molluscs carry a shell. Other members of this group include slugs, mussels, squid and cuttlefish.

This Agrodok concentrates on the farming potential of the giant African land snails (GALS), more specifically the species *Achatina achatina*, *Achatina fulica* and *Archachatina marginata*. These belong to the family Achatinidae, a diverse group of large pulmonate land snails, originally from western, eastern, and southern Africa, with long slender shells. Their size ranges from 3 cm to 25 cm. The 14 genera are: *Achatina*, *Archachatina*, *Atopochochlis*, *Bequeartina*, *Burtoa*, *Columna*, *Callistpepla*, *Lignus*, *Limicollaria*, *Limicolariopsis*, *Lissachatina*, *Metachatina*, *Periderrriopsis* and *Pseudachatini*. They mostly live in jungles in tropical countries, but some may live in grassland. They primarily feed on fruits and leaves. They are easy to find and not difficult to rear. They lay several batches of eggs each year. Generally, they are quite easy to care for, being able to put up with a range of conditions.

Essentially, a snail consists of two parts, the body and the shell. The body is divided into three parts – the head, the foot and the visceral mass. The head is not well demarcated and carries two pairs of retractable tentacles. One pair of tentacles is far longer than the other and contains the eyes in the knobbed end. The long, muscular foot occupies almost the entire ventral surface and, like the head, is not clearly demarcated from the rest of the body. A shallow longitudinal groove runs along the centre of the foot. The hump-shaped visceral mass is housed in the shell above the foot. It contains the digestive, reproductive, and respiratory organs.

The skin over the visceral hump secretes a large calcareous shell (98% of the shell is made up of calcium carbonate). In most species the shell

accounts for about a third of the body weight. It is the snail's protective casing. Whenever danger threatens, the snail withdraws its body into the shell.

View from above

Shell

Body

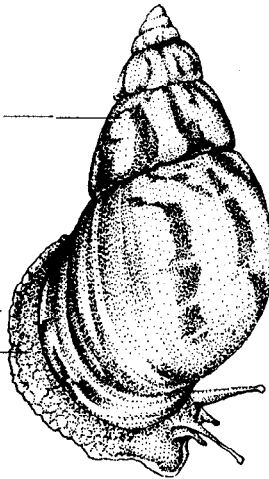

Side view

Foot

Head

Eyes

Tentacles

Mouth

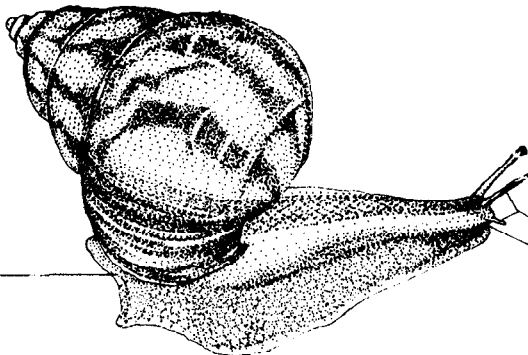

*Figure 1: The main anatomical features of a typical snail*

Although snails are hermaphrodites (i.e. they have male and female parts), in most species the individuals mate with each other before laying eggs.

## 2.2 Suitable tropical snail species for farming

A list of edible snail species of African origin is provided below. Europe and North America have over 20 edible species, of which the most popular are petit-gris or the small grey snail, *Helix aspersa*, the Burgundy snail, *H. pomatia*, and escargot turc or the snail of Turkey, *H. lucorum*. Snail meat of these species is known as 'escargot' in France; snail meat of GALS is sometimes exported from Africa and sold as 'escargot achatine'.

The most popular edible snails in West Africa are the giant snail, *Achatina achatina*, and the big black, *Archachatina marginata*. Local names are given in the list below. Most studies on snails in West Africa have concentrated on these two species and on the garden snail, *Achatina fulica*. In Ghana *Achatina achatina* is considered the most prized species for eating, followed by *Archachatina marginata* and then *Achatina fulica*.

### Edible snail species of African origin

*Achatina achatina*. Common name: giant snail, tiger snail (Ghana)

Local names (corresponding language within parentheses):

Gambia: honuldu

Sierra Leone: konk

Liberia: dain (Nano), drainn (Gio)

Ghana: abobo (Ewe), elonkoe (Nzima), krekete (Hausa), nwapa (Akan), wa (Ga), weJle (Dagarti)

Nigeria: katantawa (Hausa), ilako, isan (Yoruba)

East Africa: konokono (Swahili)

*Achatina fulica*. Common name: garden snail, foolish snail (sometimes also called the giant African snail)

Ghana: nwa (Akan)

Northern tribes of Ghana, Burkina Faso, Togo, Nigeria: kreteke

Nigeria: eesan or ipere (Yoruba)

Kenya: ekhumuniu (Luhya), kamniyo (Luo)

East Africa: konokono (Swahili)

*Archachatina marginata*. Common name: big black snail, giant African land snail

Liberia: proli (Kepelle)

Ghana: pobere (Akan)

Nigeria: igbun (Yoruba), ejuna (Ibo)

Other edible species exist, but they are of minor, local importance. The local name usually refers to all edible snail species in the country. Figure 2 shows the distribution, in Africa, of the three species on which this booklet concentrates: *Achatina achatina*, *Archachatina marginata*, as well as the (reputed) original source area of *Achatina fulica* in East Africa.

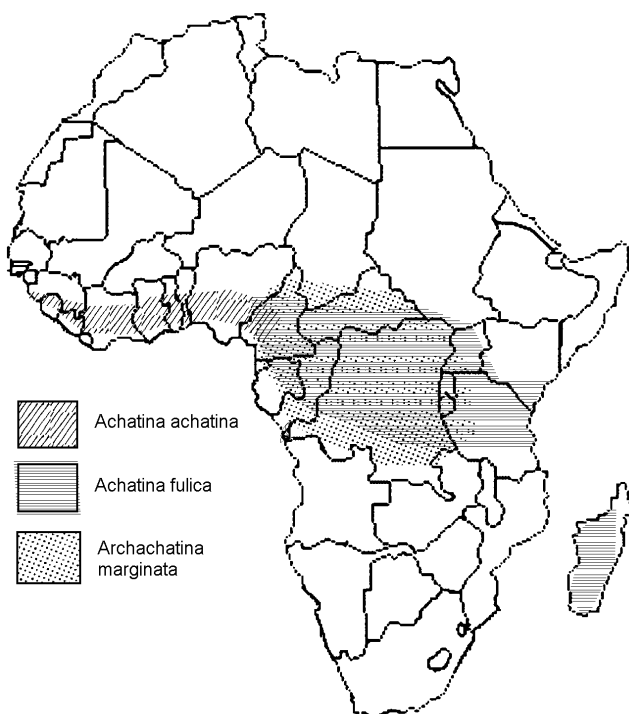

Figure 2: Approximate original distribution of the 3 GALS species discussed in this Agrodok

To avoid confusion, this Agrodok refers to the three snail species discussed by their scientific (Latin) name.

## 2.3 *Achatina achatina*

*Achatina achatina* (giant snail, tiger snail), a widely distributed species in West Africa (particularly in Benin, Côte d'Ivoire, Ghana, Liberia, Nigeria, Sierra Leone and Togo), can be considered a good candidate for snail farming in most areas of West Africa, although it requires higher humidity than the other two species and needs a longer growing time to reach sexual maturity.

### Description

*Achatina achatina* snails are reputedly the largest land snails in the world. Although usually much smaller, they can grow up to 30 cm in body length and 25 cm in shell height. Average adult shell length is 18 cm, with an average diameter of 9 cm. The conically shaped, fairly pointed shell is brownish with a characteristic stripe pattern (hence the name tiger snail).

### Distribution

*Achatina achatina* originates from the West African rainforest belt, from Guinea through Nigeria. Because *A. achatina* is the most prized species for consumption in Ghana it is becoming increasingly rare in the wild.

Several ecotypes (locally adapted populations of *A. achatina*) can be found, with differences in growth rates, size, aestivation (dormancy) patterns, colour and even flavour. The differences in size may be explained partly by differences in the length of the aestivation period; the shorter the aestivation period, the longer the feeding period and the larger, therefore, the ecotype.

A study of the three ecotypes in Ghana, known as donyina, apedwa and goaso, showed significant differences between them. The apedwa snails had the shortest aestivation periods, the donyina snails the long-

est. The apedwa snails were the largest of the three ecotypes; some were twice the size of *Donyina* snails. In Ghana, this ecotype would be recommended as the best candidate for snail farming.

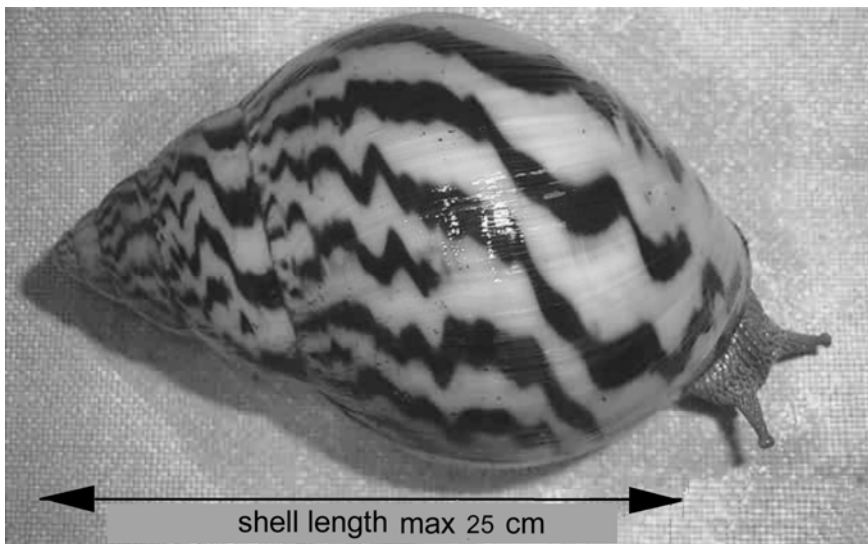

Figure 3: *Achatina achatina*

### **Growing conditions**

The species prefers warm conditions, 25-30 °C and a relative humidity of 80-95%. *A. achatina* is said not to be the easiest species to farm because of the very steady conditions it is used to in the wild: a practically constant 12/12 photoperiod, only extending to 13/11 for about 3 months, and a temperature difference between night and day of only 2-4 °C. Even in the most humid areas of West Africa the snail, in its natural habitat, buries itself for aestivation during the drier months.

### **Life history**

*Reproduction.* *Achatina achatina* reproduces by self-fertilisation. Unlike in many other species, reproduction is not preceded by coupling, although it is not unusual to find two snails in close proximity.

Studies (Hodasi, 1979) indicate that the species breeds in the main rainy season (April-July in Ghana).

*Laying.* Laying usually takes place in the late evening and night. Eggs are laid in clutches of 30-300 eggs. They are broadly oval, dirty yellowish, 8-9 mm long and 6-7 mm wide. Eggs are deposited in dug-out holes about 4 cm deep. When small clutches of eggs are laid, a second laying is indicated, and sometimes a third.

*Hatching.* Usually, the eggs hatch 2-3 weeks after laying, with a range of 10-31 days, depending on temperature. *A. achatina* has a high hatching rate of 90+%; even 100% hatchability is not uncommon.

*Hatchlings.* The baby snail has a thin shell membrane which calcifies progressively. Although this period is characterised by rapid growth, the snails are able to survive the first few days (5-10 days) after hatching without food.

*Juveniles.* The juvenile phase covers the period from 1 or 2 months to the stage of sexual maturity (14-20 months). During this period, the snail accepts a much wider range of food. At the end of the period, the shell is well formed and the snail weighs between 100 and 450 g. Differences in growth rates of the various ecotypes are very evident during this period.

*Adults.* The adult phase starts when the snail reaches sexual maturity. Not all adult snails lay eggs each season. An average life expectancy is 5 to 6 years, although there are reports of snails surviving up to 9 or 10 years.

## **2.4 *Achatina fulica***

### **Description**

*Achatina fulica* (garden snail, foolish snail) is a large snail, reaching 20 cm in length or occasionally more, with a shell length up to 20 cm and a maximum diameter of 12 cm. The conical, spiralled shell is pre-



dominantly brown with weak, darker banded markings across the spiral. Colouration is highly variable, depending on diet. A mature snail averages 250 g in weight.

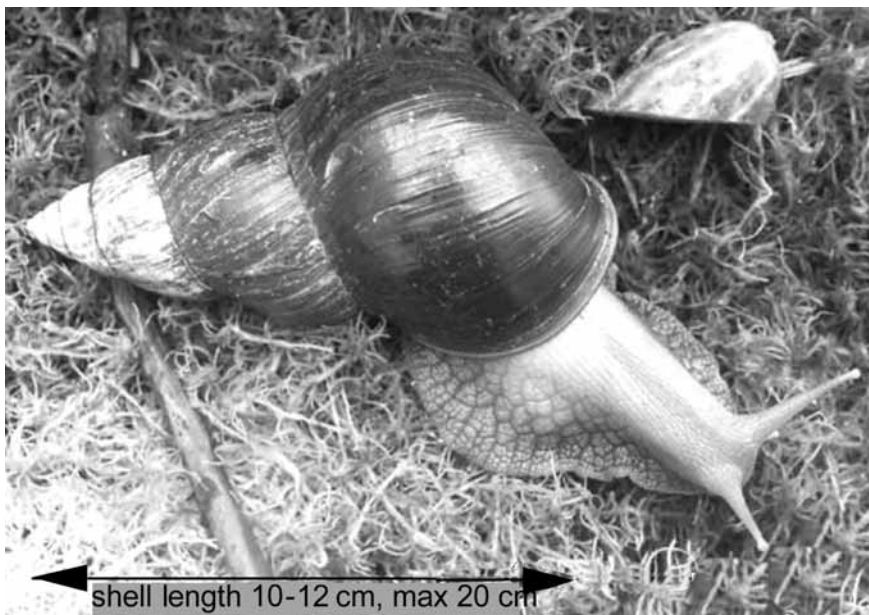

Figure 4: *Achatina fulica*

### **Distribution**

The species originated in the coastal regions of East Africa (Kenya, Tanzania), and spread by the 19<sup>th</sup> century into Southern Ethiopia, Southern Somalia, and Northern Mozambique. During the 19<sup>th</sup> century it was introduced into India and the Indian Ocean islands. During the 20<sup>th</sup> century it was introduced, sometimes intentionally, into South East Asia, East Asia (Taiwan, Korea, and Japan), Australasia and the Pacific, the USA (now eradicated in various states), the Caribbean, Central America and South America (Brazil).

### **Growing conditions**

The species is highly adaptable to a wide range of environments, modifying its life cycle to suit local conditions.

## **Life history**

*Reproduction.* Without delays because of aestivation or hibernation, snails will reach sexual maturity in less than a year (even as early as 5 months under laboratory conditions). Reciprocal copulation (6-8 hours) must occur to produce viable eggs.

*Laying.* The small (4 mm in diameter) yellowish-white eggs are laid in clutches of 10-400 eggs within 8-20 days of copulation, usually in nests excavated in the soil. Repeated layings may result from one copulation, as sperm is stored in each snail.

Egg laying frequency depends on climate, particularly on frequency and duration of the rainy seasons: up to 500 eggs per year in Sri Lanka, 300 per year in Hong Kong, and 1000 per year in Calcutta.

*Hatching, hatchlings.* Upon hatching, the hatchlings consume their eggshells (and unhatched siblings), remaining underground for 5-15 days and feeding on organic detritus. Eventually they feed primarily on plants at night, returning to roost before dawn.

*Juveniles.* Animals with shell lengths of 5-30 mm apparently cause the most damage to plants.

*Adults.* The snails may reach sexual maturity in less than a year. Larger snails continue to feed on plant materials, but feed increasingly on detritus as they age. Normally, they live for 3-5 years.

## **Significance as a pest**

The species causes considerable economic damage to a wide variety of commercial crops. In most parts of the world, the amount of damage is greatest when the species is first established; during this period, snails are usually very large and their populations can become immense. This is followed by a stable population phase, and then finally a period of decline.

## Parasitology

*Achatina fulica* is reported to be an intermediate vector of the rat lungworm *Angiostrongylus cantonensis*, which can cause eosinophilic meningoencephalitis in humans; as well as of a gram-negative bacterium, *Aeromonas hydrophila*, which can cause a wide variety of symptoms, especially in persons with compromised immune systems.

## 2.5 *Archachatina marginata*

### Description

*Archachatina marginata* (big black snail, giant African land snail) is a large snail, generally growing to about 20 cm and a live weight of 500 g. The shell is much less pointed than the *Achatina* species, the roundness being especially obvious in young animals. Striation on the shell may give the appearance of a 'woven' texture. The head of the snail is dark-grey; its foot is a lighter shade.

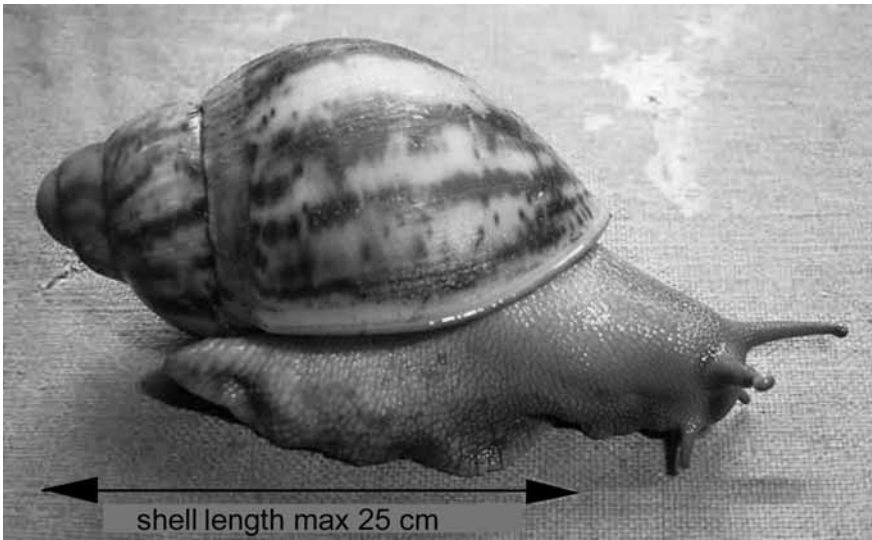

Figure 5: *Archachatina marginata*

This species has been the object of a series of stocking and feeding experiments in Nigeria (discussed in Chapter 5).

### **Distribution**

*Archachatina marginata* is native to the humid African rainforest belt, from Southern Nigeria to Congo, but is now found in other parts of the African rainforest zone.

### **Growing conditions**

In the Nigerian experiments, juvenile growth was found to be inversely proportional to temperature, falling sharply at temperatures  $> 30^{\circ}\text{C}$ , and directly proportional to rainfall and humidity. Body weight gain slows down significantly during the dry season (December to March in Southern Nigeria, where the breeding trials took place).

### **Life history**

*Reproduction.* The species reaches sexual maturity at an age of around one year, when the individuals reach a live weight of 100-125 g. Reciprocal copulation must occur to produce viable eggs.

*Laying, eggs.* The eggs are comparatively large at  $17 \times 12$  mm, with an average weight of 4.8 g in a Nigerian stocking trial. For that reason the number of eggs per clutch is low, 4-18 eggs. Eggs are laid in the soil at a depth of about 10 cm.

*Hatching, hatchlings.* The incubation period, from egg to hatchling, is around 4 weeks. Hatchlings have a thin, transparent shell; they generally remain in the soil for 5 to 7 days before emerging, but sometimes wait even longer. Because of the relatively high weight of the eggs the number of hatchlings from a clutch is low compared to the other two species. During the first weeks after emerging, hatchlings repeatedly burrow into the soil.

*Juveniles.* In laboratory trials shell length of the juvenile snails increased by an average of 0.33 mm/day for the first 8 months (c. 8 cm),

slowing down to 0.2 mm/day at 15 months. Shell length hardly increases after that time.

*Adults.* The snails reach sexual maturity at around 10-12 months (Plummer, 1975).

## 2.6 Climatic and environmental requirements and restrictions for raising snails

From the descriptions of the three major GALS species it is clear that snails, as cold-blooded animals, are sensitive to changes in atmospheric humidity and temperature. GALS, especially *Achatina fulica*, are able to put up with a range of conditions, but when temperature and/or humidity are not to their liking, they go into dormancy. The snail retracts its entire body inside its shell, sealing off the opening with a white, calcareous layer to prevent water loss from the body (see figure 6). This reaction is typical of all snail species.

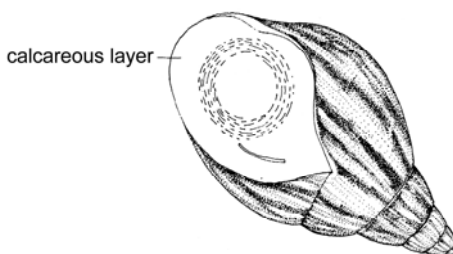

*Figure 6: Aestivating snail sealed into its shell by a calcareous layer*

Snails aestivate if the *temperature* is too high, > c. 30 °C, or if *air humidity* is too low, < c. 70-75% relative humidity.

Snails hibernate if the *temperature* drops below c. 5 °C.

For the snail farmer the result is the same: his (or her) snails become inactive and stop growing, losing valuable growing time, while expenses for housing, tending and protection continue.

Consequently, it is in the snail farmer's interest to prevent, or at least reduce, dormancy

- by selecting the most favourable site for the snail farm (Chapter 3)
- by providing good housing for the snails (Chapter 4)
- by providing good feed and ensuring good snail farm management (Chapters 5, 6).

Obviously, it is possible to farm snails in a completely controlled environment, but this would require considerable investment costs, and is therefore presumably outside the scope of the farmers for whom this Agrodok is intended. Without artificial climate control, successful commercial snail farming is more or less restricted to areas with the following characteristics:

- Temperature: a steady year-round temperature of 25-30 °C, and a low fluctuation between day-time and night-time temperatures.
- Day-length: a fairly constant 12/12-hour photoperiod throughout the year.
- Air humidity: a year-round relative air humidity of 75-95%.

These conditions correspond to the tropical rainforest climate zones – and they work best when there is no pronounced dry season or strong fluctuations.

## **2.7 Cultural and religious restrictions on handling and eating snails**

Certain religions, notably the Islamic and Jewish faiths, specifically prohibit eating snails or snail meat – a fact to be considered when planning a snail farming venture in regions where these religions are present or dominant.

Local customs or cultural preferences may prevent people from eating or even handling snails – again a factor to take into account before embarking on snail farming.

## 3 Choosing a site

### 3.1 General considerations

Snails are adept at escaping from enclosures. A priority in setting up a productive snail farming venture, therefore, is to construct escape-proof housing. There are several types of snail housing (snaileries) to choose from, depending on the size of the venture; see Chapter 4. The first step, however, is to select an appropriate site.

The main factors to consider in site selection are the following:

- (Micro)climate
- Wind speed and direction
- Soil characteristics
- Safety, protecting the snails from diseases, predators and poachers

Optimal site selection helps to prevent, or at least reduce, dormancy (see section 2.6). Factors such as temperature and humidity and soil characteristics that influence snail survival and growth are discussed below.

### 3.2 Temperature and humidity

Snails are cold-blooded; they thrive best in areas with moderate temperatures and high humidity. In West Africa, temperatures in the areas where most edible species are found do not fluctuate greatly. However, there are significant fluctuations in air humidity, which have a pronounced effect on the GALS species dealt with in this publication. In their natural surroundings, snails go into dormancy during the dry season (see section 2.6 and Figure 6).

Relative air humidity should not be near saturation, because it would encourage the development of harmful bacteria and fungi.

In outdoor situations, it is clearly impossible to control climatic factors. However, the magnitude of temperature and humidity fluctua-

tions is reduced in areas of relatively undisturbed forest or fairly dense vegetation cover. Such sites should be preferred to open grassland or farmland areas.

Obviously, snails can be reared in a completely controlled, indoor environment, but at a price. Whether the investment will be profitable depends on one's financial resources, local production costs per kg snail meat, and marketing options.

### 3.3 Wind speed and direction

Wind accelerates moisture loss in snails. To prevent snails from drying out, snaileries should be situated in sites that are protected from the wind. Downhill sites are usually the most suitable, preferably those with good tree cover to reduce wind impact. Planting (fruit) trees around snail pens will help to reduce wind speed and improve the micro-climate. It will also protect the snails from scorching sun or torrential rain.

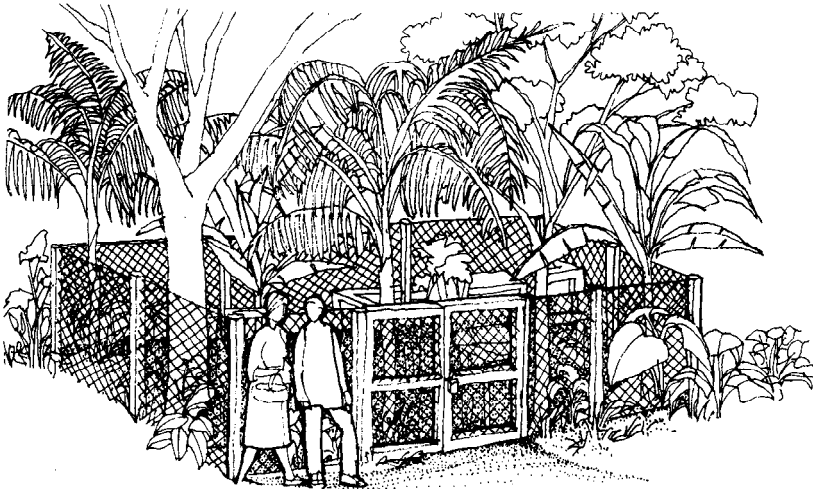

*Figure 7: General view of an open free-range snail pen, with multi-storey tree cover acting as a windbreak and reducing loss of water from the soil.*



### 3.4 Soil characteristics

Soil is a major part of a snail's habitat. Soil composition, water content and texture are important factors to consider in site selection.

- The snail's shell is made up mainly of calcium derived from the soil and from feed.
- Snails derive most of their water requirements from the soil.
- Snails dig in the soil to lay their eggs and to rest during the dry season.

For all these reasons it is essential that the soil is loose and that its calcium and water content is high.

- Heavy, clayey soil that becomes waterlogged in the rainy season and compacts during the dry season is undesirable.
- Very sandy soil is undesirable as well because of its low water-holding capacity.
- Acidic soils should be avoided because acidity would interfere with the development of the snail's shell. Soils that are too acidic might be neutralised with lime to about pH 7.
- Soils with high organic matter support the growth and development of snails. In general, if a soil supports good growth of cocoyam, tomatoes and leafy vegetables, it is suitable for snail farming.
- Before introducing snails to the site, the soil should be loosened by tilling.
- Snails need damp, not wet, environments. Although snails need moisture, you must drain wet or waterlogged soil. Similarly, rain-water must run off promptly. Snails breathe air and may drown in overly wet surroundings. A soil moisture content of 80% of field capacity is favourable. In the hours of darkness, air humidity over 80% will promote good snail activity and growth.

Most snail activity, including feeding, occurs at night, with peak activity taking place 2 to 3 hours after the onset of darkness. The cooler temperature stimulates activity, and the night-time dew helps the snail move easily. Snails like to hide in sheltered places during most of the

day. In Nigeria, shredded semi-dry banana leaves are put in the snail pens for the snails to hide under during daytime.

To maintain adequate humidity and moisture levels in drier locations, misting sprayers can be used (like those used for plant propagation) – if technically and economically feasible.

Snail shells are 97-98% calcium carbonate, therefore calcium must be available to them, either from the soil or from an external source (ground limestone, egg shells and so on, see Chapter 5). Organic matter in the soil is as important as carbonates. Soils that are rich in exchangeable calcium and magnesium stimulate growth best. Calcium may also be set out in a feeding dish or trough so the snails can eat it at will.

Snails dig in soil and ingest it. Good soil favours snail growth and provides some of their nutrition. Lack of access to good soil may result in fragile shells even if the snails have well-balanced feed; the snails' growth may lag far behind the growth of other snails on good soil. Snails often eat feed, then eat dirt. Sometimes, they eat only one or the other.

Eventually the soil in the snail pens will become fouled with mucus and droppings. Chemical changes may also occur. The soil must, therefore, be changed once every three months (see Chapter 6).

## 4 Constructing a snailery

### 4.1 Choosing a system: the options

The type and dimensions of your snailery or snaileries depend, obviously, on the snail growing system you choose, and on the quantity of snails you intend to produce.

As far as **housing** is concerned, your snail farm could be extensive, semi-intensive, or intensive, in increasing order of complexity, management and financial inputs. Three options might be considered:

- Extensive system: outdoor, free-range snail pens.
- Mixed, or semi-intensive system: egg laying and hatching occur in a controlled environment; the young snails are then removed after 6-8 weeks to outside pens for growing or fattening or both.
- Intensive: closed systems, for example plastic tunnel houses, greenhouses and buildings with controlled climate.

(Note: the same options of extensive, semi-intensive, or intensive apply to **feed** and **feeding**, see Chapter 5).

Regardless of the size and type of your snail farm, the housing system must meet the following conditions. It must be:

- escape-proof; snails are master-escapists and unless prevented from doing so they will quickly wander all over your (or your neighbour's) garden or house.
- spacious, in accordance with the growing stage of the snails (hatchlings, juveniles, breeding snails, or mature snails fattened for consumption). Snails suffer from overcrowding, which impedes their development and increases the risk of diseases. Suitable rearing densities range from  $> 100/\text{m}^2$  for hatchlings to  $7\text{-}10/\text{m}^2$  for breeding snails (see Chapter 6).
- easily accessible and easy to work in or with, for handling the snails, placing feed, cleaning and other tasks.
- well-protected from insects, predators and poachers.

Different materials can be used for building snaileries, depending on price and availability.

- Decay- and termite-resistant timber. In West Africa favourable tree species are iroko (*Milicia excelsa*, local name – odum), opepe (*Naucleadiderrichii*, local name – kusia), or ekki (*Lophira alata*, local name – kaku). In South East Asia poles can be made of a species like teak (*Tectona grandis*), which is widely planted in other continents as well.
- Sandcrete blocks, or mudbricks.
- Galvanized sheets, polythene sheets.
- Chicken wire, for protection.
- Mosquito nets or nylon mesh, for covering the pens as protection against insects.
- Second-hand materials, like car tyres, oil drums and old water tanks.

In addition to car tyres, oil drums and such materials, the following types of pens might be considered for simple snaileries:

- Hutch boxes
- Trench pens
- Mini-paddock pens
- Free-range pens

## **4.2 Car tyres, oil drums**

Discarded tyres or oil drums may serve as relatively cheap snail pens. Three or four tyres are placed on top of each other, with chicken wire and mosquito mesh between the topmost tyre and the second one from the top.

Oil drums should have some holes in the bottom for drainage, be filled with good soil to a depth of 7-10 cm, and be fitted with wire plus mosquito mesh on top.

Such pens are suitable for keeping a few snails (up to about four mature snails in each container) close to the house, for private use.

## 4.3 Hutch boxes

### Description

Hutch boxes are square or rectangular, single or multi-chamber wooden boxes with lids, placed on wooden stilts above the ground at a suitable height for easy handling. The stilts should be fitted with plastic or metal conical protectors or aprons, to prevent vermin from crawling or climbing up the stilts to attack the snails in the boxes. The protectors could be made from old tins or plastic bottles. In the middle of the lid is an opening covered with wire netting and nylon mesh. The lid should be fitted with a padlock to discourage pilfering. In the floor of the box are a few holes through which excess water can drain out. The boxes are filled with sieved black soil to a depth of 18-25 cm. The box(es) should obviously be well protected from scorching sun or torrential rain.

### Application and use

Hutch boxes are useful in a semi-intensive snail breeding system. They are very suitable as hatchery and nursery pens because eggs and young snails can be easily located and observed.

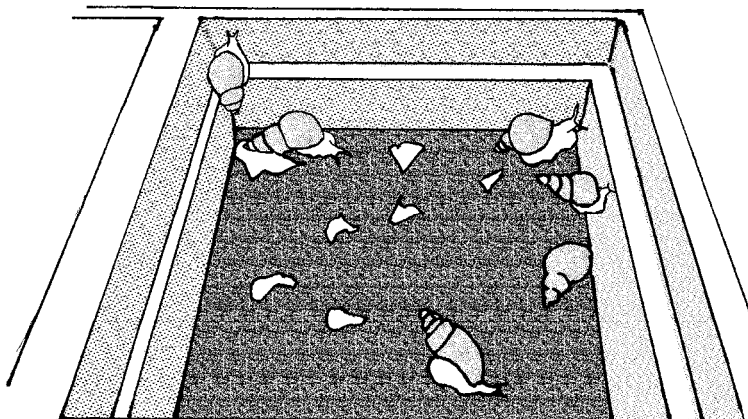

*Figure 8: Snails in one of the chambers of a hutch box*

Mature snails in larger snaileries could be transferred to hutch boxes when they start making holes to lay eggs. The breeding snails should be removed to their own pens after the hatchlings start to emerge.

The soil must be changed occasionally because an accumulation of droppings will increase the chances of disease development. A soil change every three months is adequate.

### **Advantages and disadvantages**

Hutch boxes can be placed close to the farmer's house, ensuring good supervision and protection. They are built at a comfortable working height, which facilitates feeding and handling of the snails.

Disadvantages are the cost of construction and their limited size, which restricts the number of snails that can be kept in them (some 30 hatchlings/juveniles, or about three mature snails in a box of the size shown in Figure 9). The procedure for building a hutch box is shown in the same Figure 9.

## **4.4 Trench pens**

### **Description**

Trench pens are adjoining snail pens of  $0.6 \times 0.6$  m to  $1 \times 1$  m, either dug into the ground (which must be very well-drained), or raised 40-50 cm above the ground. Outside walls and inner partitions consist of sandcrete blocks or mudbricks in either case. See Figure 10 (dug trench pen and raised trench pen).

The pens are filled with suitable soil to a depth of 10-15 cm. They are covered with wooden or steel frame lids with chicken wire plus nylon mesh, and fitted with padlocks to discourage poachers. Obviously the pens must be protected against the fierce heat of the sun or heavy rain. Shredded semi-dry banana leaves may be spread in the pens to provide shelter for the snails (see Figure 10, inset).

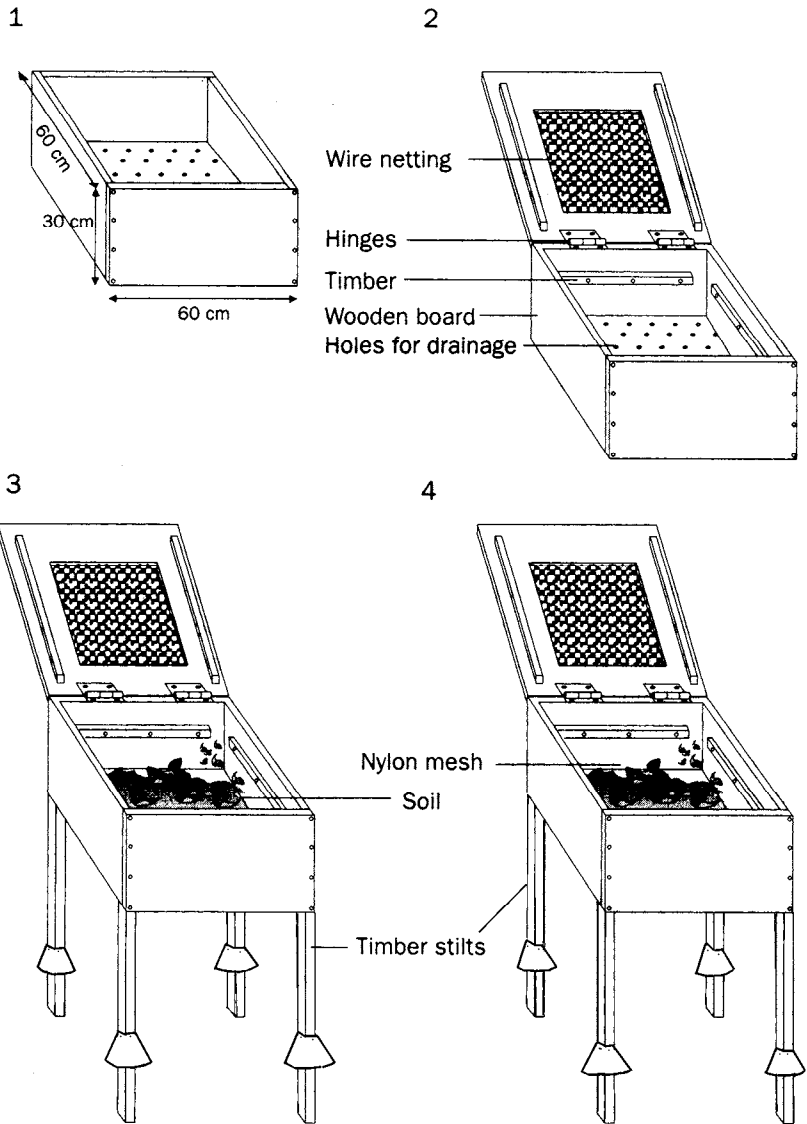

Figure 9: Sequence of building a single chamber hutch box

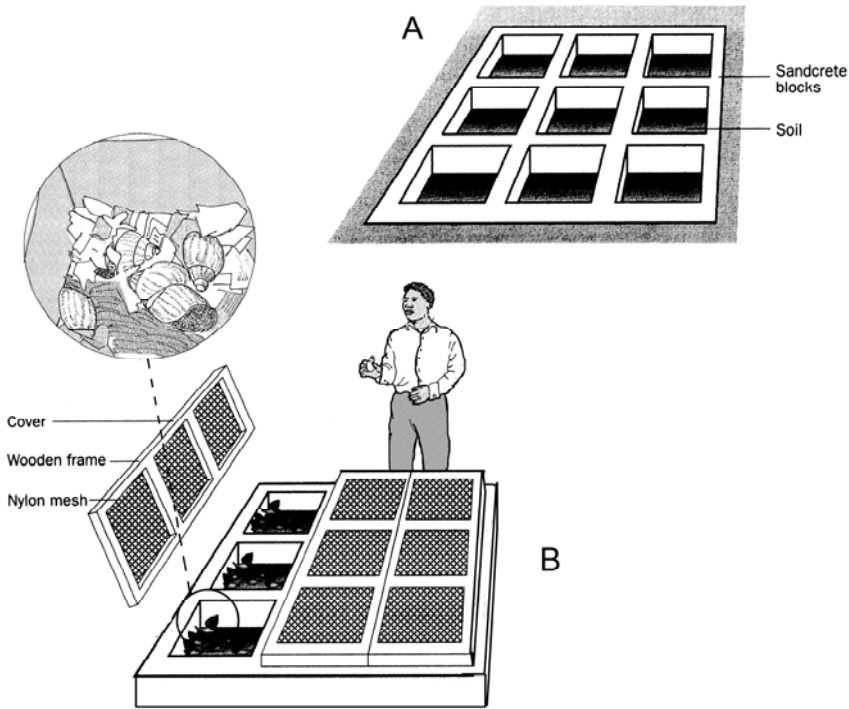

Figure 10: Two types of trench pens: A: dug in, B: raised. The inset shows *Archachatina marginata* snail crawling around in shredded banana leaves (for dimensions see Appendix 2).

### Application and use

Trench pens are suitable in semi-intensive to intensive snail growing ventures. They can be used as hatchery, nursery or fattening pens, with the number of stock being adapted to the size of the snails in each case. The snails can be moved from one pen to another according to the growing cycle.

### Advantages and disadvantages

The main advantage of a trench pen system, whether sunken or raised above the ground, is its flexibility. Snails can be moved around easily, in accordance with their size and phase in the growing cycle. The



snails are always easy to locate, for feeding, handling, selection and final sale or consumption.

The main disadvantages of trench pens are (a) construction costs (specifically of raised pens, see figure 10), and (b) the fact that the farmer has to stoop or kneel down to tend the snails.

## 4.5 Mini-paddock pens

### Description

Mini-paddock pens are small square or rectangular pens, usually within a larger fenced area. They are built of bamboo and nylon mesh as in figure 11, or of timber, chicken wire and nylon mesh as in figure 12.

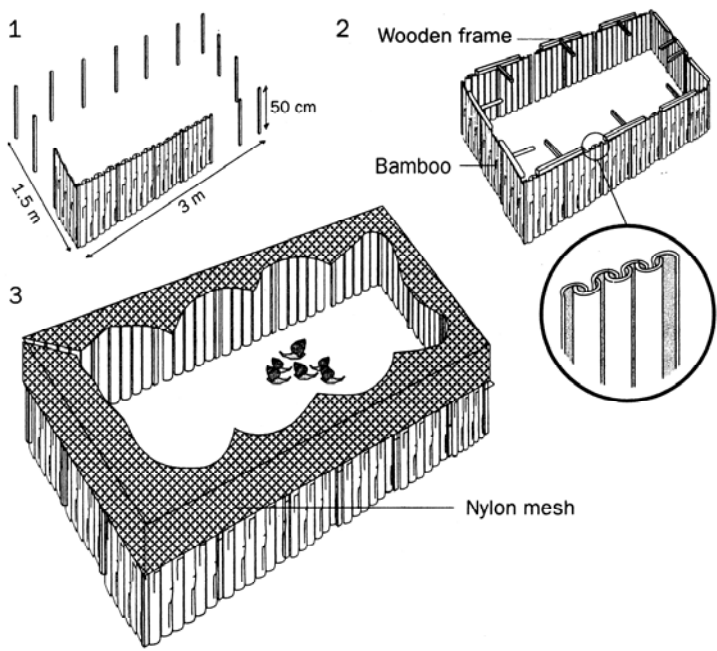
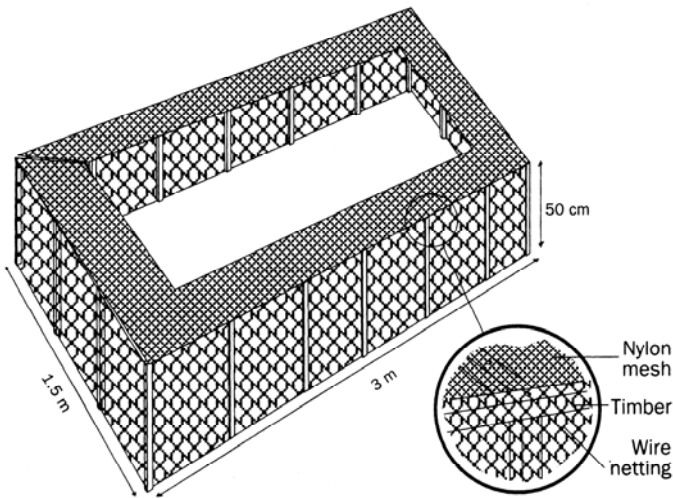

Figure 11: Sequence of building a mini-paddock pen using bamboo and nylon mesh

The walls should be some 50 cm high and be dug at least 20 cm into the ground. Wooden frames are attached to the top of the walls (extended inwards) and covered with the mesh, to prevent snails from escaping (see figure 11 and figure 12). Plants providing shelter and/or food are planted in the pens before snails are released into them. Suitable plants include cocoyam, sweet potato, fluted pumpkin, and leafy vegetables. Rectangular pens allow the farmer easier access to the whole area without having to enter the pens. Mini-paddock pens may also be constructed higher above ground, with a completely enclosed frame, and may even be roofed.



*Figure 12: A mini-paddock pen built of timber, wire netting and nylon mesh*

### **Application and use**

Mini-paddock pens, like free-range pens (see section 4.6), are suitable as fattening pens, where snails that are no longer needed for breeding are allowed to put on weight before being collected for consumption or sale. Additional snail food may be placed in the pen, but uneaten food must be removed regularly. Food and shelter plants must be replanted from time to time.

## **Advantages and disadvantages**

The advantage of mini-paddock pens is that snails grow in an environment resembling their natural habitat without much additional effort from the farmer. The limited dimensions of the pen still permit close supervision.

The main disadvantage would seem to be that the snails are not protected against predators, unless the pen is entirely closed and roofed, which makes it more expensive.

## **4.6 Free-range pens**

### **Description**

Essentially, free-range pens are large mini-paddock pens: a fenced area of up to 10 × 20 m, planted with plants, shrubs and trees that provide food and shelter from wind, sun and rain (see Figure 13). Just like in a mini-paddock pen, the vertical fence must be extended inwards, to prevent snails from escaping. If the fence is constructed of fine chicken wire mesh, the overhang is not obligatory because snails dislike crawling on wire mesh. The fence must be dug at least 20 cm into the ground. The free-range pen might even be completely enclosed and roofed.

### **Application and use**

Free-range pens may serve as the sole snail enclosure in an extensive snail farming system, or as growing and fattening pens in a semi-intensive one.

In the extensive snail farm the entire life cycle of the snail develops within the open pen: mating, egg laying, hatching, hatchling development, and growth of the snails to maturity. Snails feed on the plants provided in the pen.

In a semi-intensive snail farm the free-range pen serves as a growing and fattening pen for adult snails, which were raised through the egg-hatchling-juvenile stages in hutch boxes or trench pens.

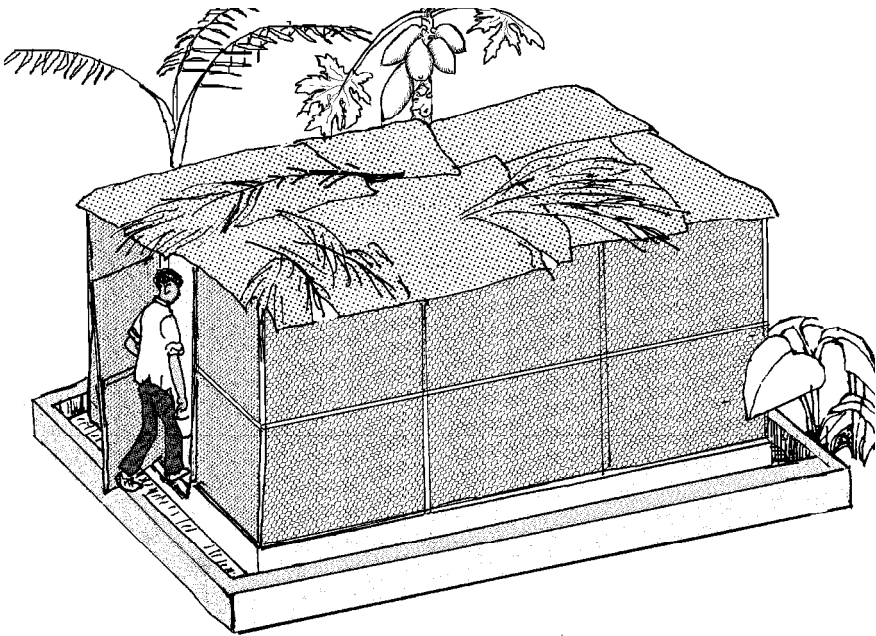

*Figure 13: Completely enclosed free-range pen on concrete slab with drains. Note shade trees and palms around, and palm fronds on top to provide shade.*

### **Advantages and disadvantages**

In an extensive system using a free-range pen the snails develop in a near-normal habitat. They will take shelter in the vegetation or the soil during the day, coming out at night to feed.

A simple fenced free-range pen is relatively simple and cheap to construct. Management is restricted to occasional replanting of food and shelter plants. If the vegetation within the pen is kept in shape, additional feeding of the snails is not necessary.

A fully enclosed and roofed pen is quite costly to build, obviously, especially if provided with a concrete apron and drain (Figure 13). Both types require the availability of land with a secure title, consider-

ing the investment involved, specifically for the fully enclosed and roofed variety.

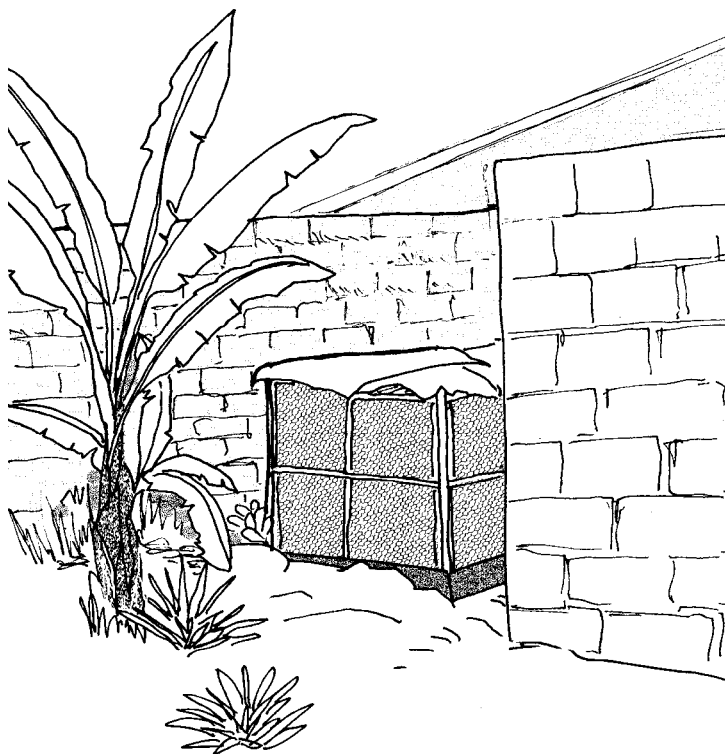

*Figure 14: Small-sized free-range snail pen in a city courtyard*

The free-range pen has several disadvantages.

- It requires more land than other types of snail farming.
- It is difficult to locate and protect eggs and small snails. This may lead to poor disease management and higher mortality compared to other snail production systems.
- It is difficult to keep track of snail performance and, for that reason, to keep useful records of inputs and output.
- In the open type of free-range pen it is more difficult to keep out predators and poachers.

Besides the natural shelter provided in mini-paddock and free-range pens, it is advisable to also provide other forms of shelter to ensure that the snails are not exposed to too much heat. For example, concave tiles or split bamboo can be placed on stones on the ground, with the concave side facing downwards. On very hot days, the soil can be cooled by sprinkling water on it.

More on rearing density and **optimal pen size** in relation to the stocking density of snails in their different growing stages can be found in section 6.3.

The materials needed for different types of snaileries are listed in Appendix 2.

# 5 Food and feeding

## 5.1 Introduction

The distinction between extensive, semi-intensive and intensive snail farming systems applies not only to **housing** (Chapter 4), but also to **feeding**.

In an extensive system snails feed only on vegetation planted in their pens specifically for that purpose, as in mini-paddock and free-range pens.

In a semi-intensive snail farm, external feed is provided to hatchlings, juveniles and possibly to breeding snails housed in hutch boxes or trench pens.

In an intensively managed snail farm, all snails, at whatever growing stage, are always provided with external feed. Snails are kept in hutch boxes or trench pens.

In very intensive farms the snails are fed a formulated snail feed mix containing all the proteins, carbohydrates, minerals and vitamins required for optimal growth. Snails are housed in boxes or trench pens.

Unless your snail farm is of the very extensive type, you will have to provide your snails with some or all the food they need for good development. This will require efforts on your part in growing or collecting snail food, or cash for buying it. Therefore, you must know what snails *eat* and what they *need*.

## 5.2 Types of snail food

### What snails eat

Snails are vegetarian and will accept many types of food. All snails will avoid plants that have hairy leaves or produce toxic chemicals,

like physic nut (*Jathropa curcas*). Young snails prefer tender leaves and shoots; they consume about twice as much feed as mature snails. As they get older, mature snails increasingly feed on detritus: fallen leaves, rotten fruit and humus. Older snails should be fed the same items as immature snails. If a change in the diet has to be made, the new food items should be introduced gradually.

### What snails need

Snails need carbohydrates for energy, and protein for growth. In addition they require calcium (Ca) for their shells, as well as other minerals and vitamins. Snail meat is low in crude fibre and fat; for that reason, these components are of minor importance in snail feed.

### Recommended food items

*Leaves:* cocoyam, kola, paw paw, cassava, okra, eggplant, loofa, centrosema, cabbage and lettuce. Paw paw leaves (as well as its fruit and fruit peels) stand out in many trials as good snail food.

*Fruits:* paw paw, mango, banana, eggplant, pear, oil palm, fig, tomato and cucumber.

Fruits are usually rich in minerals and vitamins, but low in protein.

*Tubers:* cocoyam, cassava, yam, sweet potato and plantain. Tubers are a good source of carbohydrates, though low in protein. (Cassava should be the low-cyanide type).

*Flowers:* oprono (*Mansonia altissima*), odwuma (*Musanga cecropoides*) and paw paw.

*Household waste:* peels of fruit and tuber, like banana, plantain, pineapple, yam and



Figure 15: Snail food: flowers and fruit

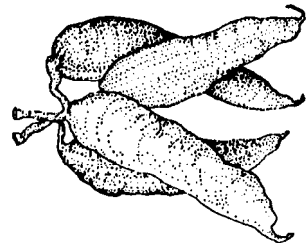

Figure 16: Snail food: tubers



especially paw paw, and leftovers like cooked rice, beans, fufu and eko. Caution: household waste must not contain salt!

## 5.3 Recommendations on natural feed

### Market waste

Because snails are vegetarians, the cheapest way to feed them is by collecting rejected but recommended food from marketplaces. At the end of any market day, some perishable vegetables and fruits still useful for snail consumption can be collected from the dumping areas. This would reduce the cost and labour of buying or cultivating vegetables and fruits only to feed snails.

### *Achatina achatina*

*Achatina achatina* feeds mainly on green leaves, fruits, tubers and flowers. Unlike other snails, it prefers leaves and fruits that are detached from the main plant. It also seems to prefer wet leaves to dry ones and appears to thrive on prunings of food plants grown in pens.

Providing *A. achatina* with a mixture of foods, rather than only one or two items, will enhance its growth. Food attractiveness is important in the nutrition of this species. If the food is appetising (e.g. paw paw) or contains a feeding stimulant, the snails will eat a lot and grow quickly. If food is unattractive or lacks a stimulant, however nutritious it may be, the snails will not eat much of it.

*A. achatina* baby snails thrive best on leafy vegetables. At all other stages, a diet made up of the following ingredients is recommended:

- *Cocoyam*. Cocoyam leaves contribute fairly high amounts of protein (2.9%), calcium (60 mg/kg) and phosphorus (52 mg/kg), and moderate amounts of thiamine (vitamin B 1) and riboflavin (vitamin B2).
- Paw paw fruit provides moderate amounts of carbohydrates and high amounts of ascorbic acid (which is a feeding stimulant for many plant-eating animals, including snails).
- *Oil palm*. The mesocarp (fleshy layer) of the oil palm is high in carbohydrates, fats and palmitate (vitamin A).

- *Supplementary vitamins.* Other food plants known to contain moderate amounts of vitamins D, E and K should be added; examples are sunflower and copra cake (vitamin D), wheat germ, lettuce and other vegetables (vitamin E), cabbage and African spinach (vitamin K).
- *Supplementary calcium.* If the soil is not high in calcium, supplementary calcium will be needed. This can be provided by sprinkling powdered oyster or snail shells or ground limestone onto leafy vegetables.
- *Supplementary minerals.* Other minerals can be provided by placing licking stones containing the mineral in the pen.
- *Water.* Clean water should be available to the snails at all times.

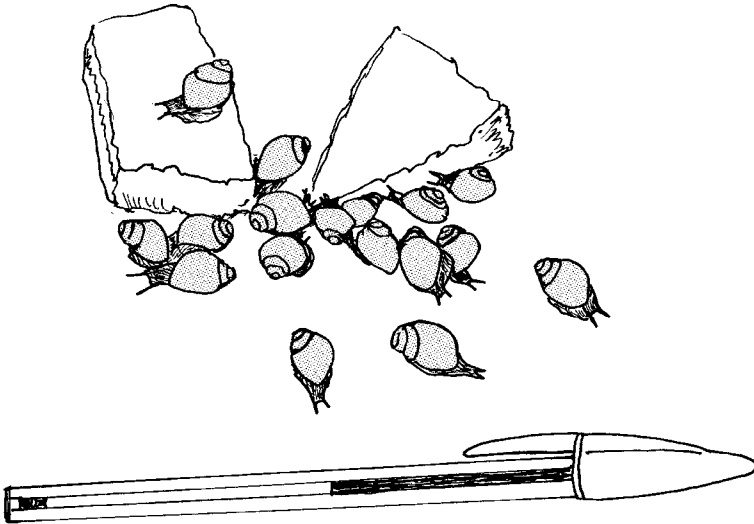

Figure 17: Young *A. achatina* snails feeding on paw paw fruit

### **Archachatina marginata**

Studies on *Archachatina marginata* show similar feeding demands, with paw paw leaves and fruits leading the list. Other common and nutritious feeds are okra, coco yam (*Dioscorea* spp.), banana, cabbage, and even cassava leaves of the low cyanide variety. Younger snails are fed tender leaves.

## Summary recommendations on natural feed

- Snails can feed on a large range of food items.
- Looking for thrown-away surplus vegetables and fruits still consumable by snails is a good way to reduce feeding costs.
- Feed containing waxy or hairy leaves should be avoided. Paw paw leaves, fruit and fruit peels stand out as excellent snail feed in many feeding trials.
- Feeds should contain protein at a level of about 20% of diet dry matter for optimum development. Paw paw leaves, fruit and peels are a good source of crude protein.
- For strong growth and good shell development, powdered calcium sources from egg shells, limestone, wood-ash, oyster shells (crushed), or bone meal, should be added to the feed at a level of about 15 to 20% of diet dry matter. Crushed oyster shell calcium is best. Increasing the amount of calcium above 20% of diet dry matter results in thicker shells, not in more snail meat. (Note: 20% Ca may seem like a lot, but remember this is a proportion of dry matter and customary snail feeds are made up mainly of water.)
- Snails need water! Most is supplied by the food they consume, but additional water must be supplied in the growing pens: a water-soaked sponge or a dot of cotton wool for hatchlings and juveniles, in shallow dishes (otherwise the snails may drown) for mature and breeding snails.

## 5.4 Recommendations on formulated feed

As land pressures force people to move from extensive farming, in which natural foods are abundant, to semi-intensive farming, it may become necessary to introduce formulated feeds. Studies in Ghana in which poultry feed was used in snail farming showed that this formula has good potential in growing *A. achatina*.

In *Archachatina marginata* snail farming in Nigeria, commercially formulated feeds are sometimes used, but they are rather expensive. You can mix a snail feed formula yourself, using the following ingredients and ratios (in kg per 100 kg mix; recipe from Nigeria):

*Table 1: A self-mix snail feed formula*

<b>Ingredients</b>	<b>kg</b>
Maize	31.3
Groundnut cake	10
Soy bean meal	25
Fish meal	4
Wheat offal	16
Palm kernel cake	4.2
Oyster shell	8.05
Bone meal	1.2
Premix vitamins & minerals	0.25

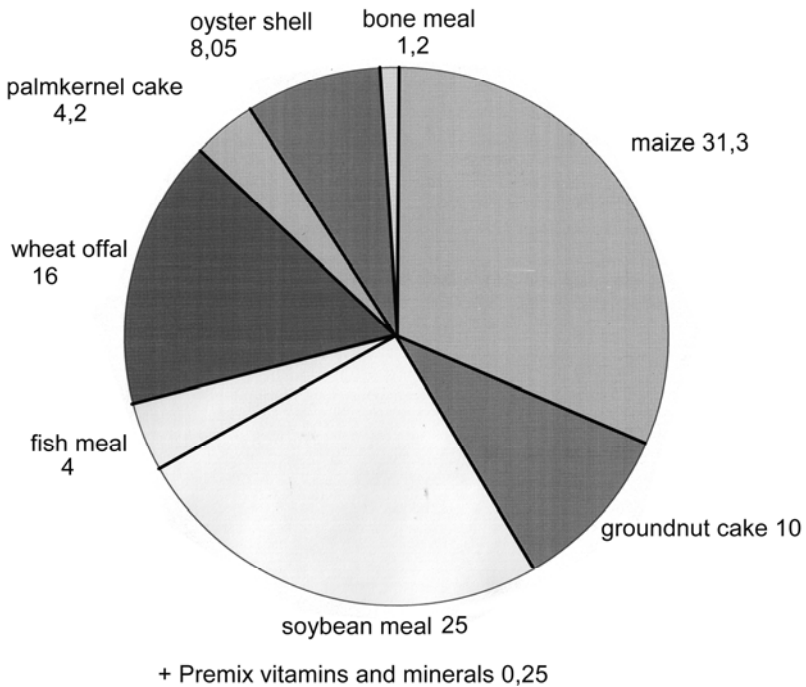

*Figure 18: A self-mix snail feed formula*

In France, a compound feed commonly used for *Helix* species contains calcium, phosphorus, sodium chloride and vitamins A, B1, D, E and K. This sort of feed, formulated to meet the snail's specific nutritional requirements, has the effect of considerably reducing the growth period. Formulated food for *H. aspersa*, for example, reduced the growth period from hatching to harvest by 10 months, from 27 to 17 months.

## 5.5 Feeding and growth

### Feeding management

- Growth is highly dependent on ambient temperature and humidity. At high temperatures ( $> 30\text{ }^{\circ}\text{C}$ ) and relatively low air humidity ( $< c. 70\%$ ) growth slows down or stops, because snails go into dormancy. This should be avoided as much as possible, by good snail housing and management.
- Optimum stocking density obviously depends on age and size of the snails. For hatchlings and juveniles stocking rates of  $100/\text{m}^2$  or more are applied; for mature breeding snails stocking should not exceed  $10\text{-}15\text{ snails}/\text{m}^2$ . Overcrowding results in reduced growth and increased mortality!
- How and when to feed snails. In their natural habitat snails are nocturnal animals, hiding during the day and coming out at night to feed. Their main feeding time starts from around two hours after sunset. For best results the snail farmer should not put snail feed in his pens before nightfall. Uneaten snail food should be removed from the pens daily; otherwise, it will attract vermin and/or diseases. To facilitate cleaning, the snail food might be placed on a flat dish, a concrete slab, or an oil drum lid, placed within the pen (figure 19).

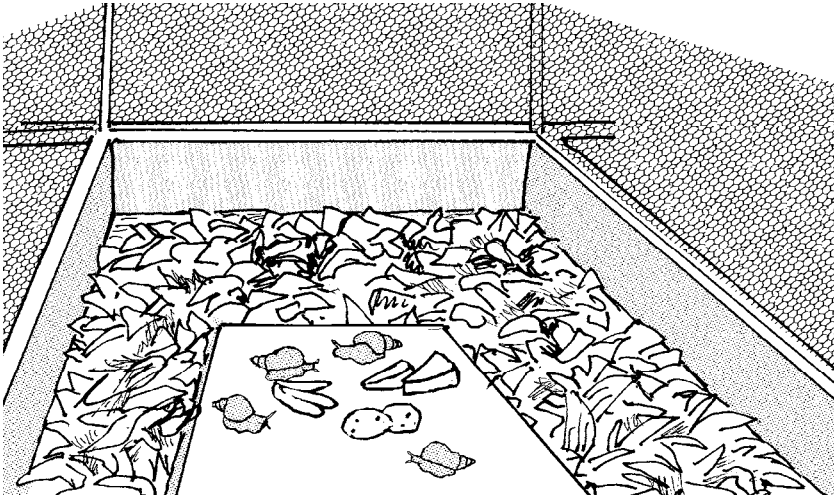

Figure 19: Concrete slab in Nigerian snail pen used for placing snail food.

### Snail growth

It takes about 15 months for *Achatina achatina* to reach full maturity; so they are not fast-growing animals for the quantity of food they eat and the amount of consumable meat they produce. The other GAL species discussed in this booklet grow relatively slowly as well. Studies on diet and growth indicate growth rates from 5 to 20 g live weight per month, corresponding to about 2 to 8 g edible snail meat per month when the average dressing percentage of around 40% is considered (the remaining 60% of the snail's weight is made up mostly of its shell, body fluid and intestines).

An FAO brochure on snail breeding indicates that an annual production level of 12-13 kg edible snail meat ('escargot') can be expected from a 5 × 5m snailery of the free-range type (see Further Reading).

Studies on the growth rate of snails (mainly *Archachatina marginata* in Nigeria) fed on different diets suggest that growth rates are influenced by the genetic make up of snails. Generally the offspring of the larger ecotypes grow faster.

## 6 Breeding and management

In extensive snail farming in free-range pens, the snails follow their natural life cycle. Interference from the snail farmer is restricted to the daily removal of any dead snails, refilling watering troughs, keeping the soil moist in the dry season, and occasionally harvesting mature snails for sale or for the cooking pot.

In semi-intensive or intensive snail farming the farmer will actively manage the snails during the successive stages of their life cycle: egg laying, hatching, growing and maturity. Management activities proceed in tune with the snails' life cycle, which in turn follows the seasons with their periods of snail activity and of dormancy (aestivation during the dry seasons). (Note: Domesticated snails continue to lay eggs in the rainy and dry seasons; Omole *et al.*, 2007).

In either case, farmers must obtain breeding stock to start their snail farms. Snails might be obtained directly from the bush, from hawkers or markets, from other snail farmers, or from research institutes.

### 6.1 Selecting breeding stock

It is recommended to use sexually mature snails, weighing at least 100-125 g, as initial breeding stock. Farming should preferably start at the onset of the wet season, because that is the time snails normally start to breed.

Until snail farms become self-sustaining, farmers may have to collect snails from the wild or buy them cheaply in the peak season and fatten them in captivity in the off season. In relatively undisturbed forest areas, snails can be collected on days following rains. Snails are active at night and on cloudy or foggy mornings. During the day they tend to keep well hidden, so it is best to collect them at night or early in the morning, when the sun is low and the humidity high.

Farmers purchasing breeding stock from snail gatherers or from the market should expect a fairly high level of mortality as a result of poor handling and the adjustment to different foods.

The most reliable way of obtaining parental stock is from known breeders, or from agricultural institutes. Such parent snails might be more expensive than snails from other sources, but they are better and safer because they have been properly fed and managed from hatching, and have not been damaged during collection and subsequent handling.

Once the snail farm is established, farmers should select breeding stock from their own snails. Breeding stock must be selected in the wet season preceding aestivation, based on the following attributes:

- *Fecundity* (expected number of eggs, based on numbers laid in previous seasons)
- *Hatchability* (percentage of eggs likely to hatch out of the total number laid)
- *Establishment rate* (percentage of snails likely to survive after hatching)
- *Growth rate*
- *Shell strength*

Simple records kept by snail farmers can provide the necessary information. As a general rule, the fastest growers with the strongest shells should be selected as breeding stock. The stronger its shell, the better the snail is protected against predators.

## **6.2 Nursery**

Snails selected as breeding stock are placed in hutch boxes or trench pens, which must contain feed and water troughs.

Some farmers let snails lay eggs in the grower pens, and then transfer the eggs to the nursery boxes or pens, but this is not recommended. It



may be difficult to locate the eggs, and the eggs may be physically damaged during the transfer.

A breeding snail may lay one to three egg masses (clutches) per season. The number of breeding snails placed in a hutch box depends on the fertility of the group and on the number of young snails required. The latter depends on the pen space available. After egg laying, the parent snails should be returned to their grower pens.

In *A. achatina*, large differences have been observed in egg production within and between populations. The average size of egg mass produced by the various ecotypes studied in Ghana, for example, ranged from 38 to 563 eggs. Generally, snails lay between 100 and 400 eggs. The eggs are broadly oval and measure about 5 mm long. They are usually laid in round-shaped holes dug 2-5 cm deep in the soil (figure 20). Occasionally they are laid on the soil surface or at the base of plants. Snail eggs require a certain amount of warmth to induce hatching. They usually hatch 12-20 days after laying.

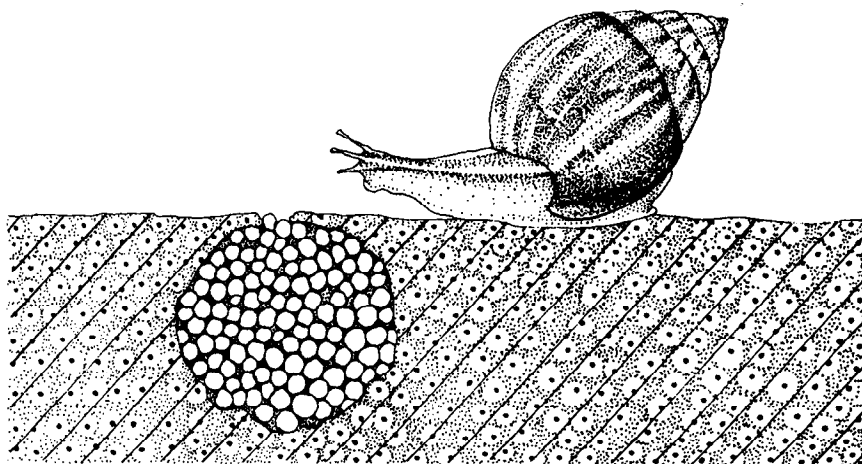

Figure 20: Eggs laid in a hole dug in the soil

In *A. achatina*, the baby snails have light-brown shells with black stripes. They should be kept in the boxes and fed on vegetable or fruit leaves (like cocoyam and paw paw leaves), fruits (preferably paw paw), powdered oyster shells and water until they are big enough to move to grower pens. Young snails do best if they are kept with snails of the same size.

The eggs of *Achatina fulica* are small (4 mm) and are laid in clutches of 10 to 400; usually a parent snail lays several clutches in a year. Hatchlings remain 5-15 days underground before emerging.

The eggs of *Archachatina marginata* are quite large (17 × 12 mm) and egg clutches are small (4-18 eggs). A parent snail may produce several clutches a year. The incubation period is around 4 weeks. Hatchlings remain underground for 2-5 days after hatching.

### **6.3 Rearing density**

Density affects the growth and breeding capacity of snails. High-density populations tend to grow slowly, develop into smaller adults, and lay fewer clutches of eggs and fewer eggs per clutch. If the snails are very densely packed, they may not breed at all. The accumulating slime suppresses reproduction. Other disadvantages of high density are the high rates of parasitism and ease of transmission of diseases.

In terms of snail weight, the recommended density is 1-1.5 kg per m<sup>2</sup> (for *A. achatina*, this would be about 15 to 25 snails per square metre). It is best to start a snail farm with as low a density as possible. As the farmer becomes more familiar with snail habits and with managing the enterprise, the numbers could be increased.

### **6.4 Seasonal and daily management**

As in any livestock farming operation, good management practices are the key to success.

Most research on farming GALS has been carried out in West Africa. Seasonal activities, as described below, follow the march of the seasons of West Africa, with breeding and egg laying in March through July. Note that domesticated snails may continue laying during the dry season as well (Omole, *et al.* 2007).

Snail breeders in other parts of the (sub)humid tropics should adapt the management cycle to local conditions.

In semi-intensive or intensive snail farming, farmers keep and care for hatchlings, growers and breeding snails in separate hutch boxes or pens.

### *Hatchlings*

Hatchlings require more humid conditions than adult snails. They should be fed tender leaves, such as paw paw and/or cocoyam, and a calcium supplement for good shell development. The soil in their pens should be kept moist and enough water should be provided. The pens should be fitted with small gauze wire mesh or nylon mesh; otherwise the small snails will escape. Hatchlings and juveniles may be kept at a density of around 100/m<sup>2</sup>.

### *Growers*

Growers should be transferred to separate pens at around 3 months of age, at a stocking density of 30-40 snails/m<sup>2</sup>. For fast growth, they might be given compound feed, rich in crude protein, calcium and phosphorus, besides their normal diet.

### *Breeders*

Breeders start to lay eggs at sexual maturity, at the age of 10 to 12 months. They should be transferred to boxes or pens at a density of 10-15 snails/m<sup>2</sup>. (*Note: stocking densities mentioned are indications. The general stocking density guideline of 1-1.5 kg snail/m<sup>2</sup> should always be kept in mind!*) soil should be loosened to facilitate egg laying. The breeders' ration must be rich in crude protein and calcium. Any eggs found on the surface must be buried promptly to a depth of 1 to

2 cm. Before hatching, the soil on top of the clutches might be loosened or removed to facilitate uniform emergence. To avoid cannibalism, the breeders must be removed to their growing pens soon after the hatchlings emerge. *Adults* no longer required for breeding are kept in fattening pens until ready for sale or consumption.

Daily management involves several activities:

### *Feeding*

Snails should be fed after sunset. The feed must not be stale or mouldy. Leftovers should be removed the following morning. Water should be replenished.

### *Housing*

Check whether wire mesh and mosquito netting are intact; repair where necessary. Clean the pens. Keep doors or covers of the snail pens closed and locked.

### *Soil*

Keep the soil moist by mulching and watering if necessary in the dry season. Never add fresh poultry droppings to the soil. Change soil in the cages every three months.

### *Hygiene*

Check pens for any dead snails; remove them immediately. Do not use insecticides or herbicides in your snailery. Handle your snails carefully and wash them with water from time to time.

### *Recording*

Record inputs and output of your snail farm daily. Include your own labour or that of family members, and inputs, like food or repairs to the pens.

## 6.5 Snail farming tools and equipment

Besides the customary gardening tools (shovel, hoe, rake, cutlass, broom), the following equipment and tools are needed in successful snail farming:

- small weighing scale, for weighing snails and feed
- measuring tape, for measuring pens and snails
- hand trowel, for digging in and cleaning out the pens
- water container and watering can, for keeping the soil moist and refilling water troughs
- water and feeding troughs or dishes
- most important: a notebook, for carefully recording inputs (e.g. labour, materials and feed) and output of the snail farming venture.

# 7 Predators, parasites and diseases

Snail farmers must be aware of several predators, parasites and diseases if mortality rates are to be kept to a minimum. Snails have many natural predators, including members of all major vertebrate groups, carnivorous snails, ground beetles, leeches and even predatory caterpillars.

Humans also pose great dangers to snails in the wild. Pollution and destruction of habitats have caused the extinction of some snail species in recent years. Human poachers pose a great danger to farm-grown snails as well!

## 7.1 Predators

The major predators a snail farmer may have to deal with are field mice, rats and shrews, frogs and toads, thrushes, crows and domesticated birds such as ducks and turkeys, lizards and snakes, drilid and carabid beetles, and millipedes and centipedes. The frogs tend to take only the young snails, while the reptiles eat both eggs and snails of all ages.

In areas with high bird predation, it is necessary to place cover nets over the pens. Keeping some of the other predators out may require building fences around the pens. The fences should be between 15 and 30 cm high and dug well into the ground. It is also advisable to set bait or traps outside the snail farm area.

Leftover food should be removed daily from pens because some predators, particularly rats and field mice, are attracted by the uneaten food. These predators can decimate a farm in a few days.

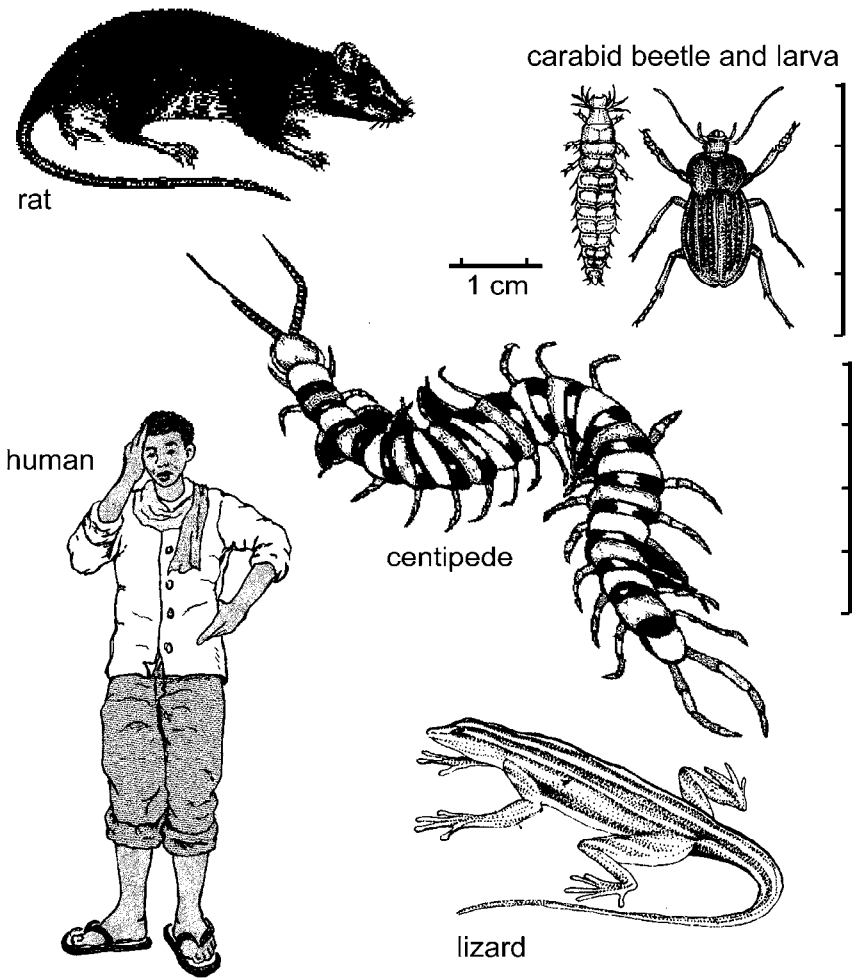

*Figure 21: Some natural enemies of snails*

However, the main predators are humans looking for a nutritious meal at the snail farmer's expense. Snail farmers must introduce any legal measures they consider necessary to protect the farm against poachers.

## 7.2 Parasites

In Ghanaian studies, the major parasite on snails was found to be a fly, *Alluaudihella flavicornis*. This species belongs to the same family as the housefly and the adult resembles the adult housefly.

*A. flavicornis* lays 20-40 eggs in the snail shell or on the snail. The eggs hatch in about one week and the small, cream-coloured worms start feeding on or in the body tissue. They feed until the body is reduced to a putrefying mass, and then pupate within the shell. After a 10-day incubation period, the adults emerge. The best protection against these flies is to cover the pens with nylon mesh.

Egg stage

20-40 eggs usually  
laid on the lip of the  
shell

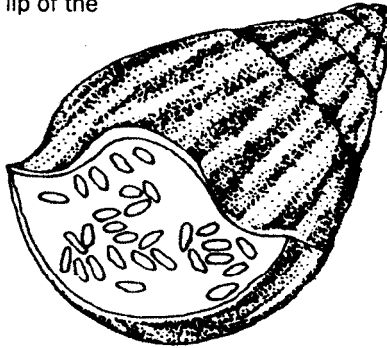

Larva stage

Cream-coloured  
larvae feed on  
snails

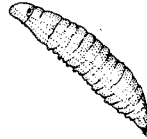

Pupa stage

Pupae attach  
themselves to  
the inner walls of  
the shell



Adult stage

Adults resemble  
the housefly but  
are bigger and  
yellowish-brown



Figure 22: The entire life cycle of *Alluaudihella flavicornis*, a parasite of *Achatina achatina*, takes 25-40 days.



Ectoparasitic mites are sometimes found on the snails in hutch boxes. They seem to be secondary parasites, usually occurring on inactive snails.

Some nematodes are known to attack European species of edible snails. However, there are no known reports of nematodes parasitising *A. achatina*.

### 7.3 Diseases

Little is known of the diseases which attack *A. achatina* in West Africa. As snail farming increases in popularity, more research will probably focus on this area. The main disease that has been reported to date is a fungal disease, spread through physical contact by the snails licking slime from each other's bodies.

The two major diseases affecting European species may also affect African species, because the organisms that cause these diseases do occur in the natural range of *A. achatina*. The first is a bacterial disease, caused by *Pseudomonas*; it leads to intestinal infections that may spread rapidly amongst dense snail populations. The second disease is caused by the fungus *Fusarium*, which parasitises the eggs of *Helix aspersa*. The affected eggs turn reddish-brown and development stops. This disease is commonly referred to as 'rosy eggs disease'.

Basic hygiene prevents the spread of diseases. Pens should be cleaned out regularly to remove excreta and uneaten food, as well as any other decaying matter that may serve as substrate for pathogenic organisms. It is also advisable to sterilise the soil in hutch boxes by steaming or heating every time they are being prepared for a new batch of egg clutches (i.e. when the breeders are transferred to the boxes for egg laying).

# 8 Processing and consumption of snail meat

## 8.1 Processing

### Harvesting and storage

The age and size at which snails should be collected from the snailery obviously depends on the farming objective: whether the snails are grown for personal use or for the market. Snails grown for personal use can be harvested according to the farmer's needs; whereas customer preferences dictate the optimum size and consequently age of snails harvested for the market. Snails usually need to grow for at least one year to reach their proper size and weight. It is recommended to harvest snails by the time they reach two years, because after this age their rate of growth slows down.

Snails are picked by hand, at nightfall, when they become active and are easier to find and collect. They need to be put carefully into a basket, box, crate or sack, to avoid damaging the shell, which would lower their market value. Never put more than 10 kg snails together in whatever storage receptacle you use, to avoid cracking or crushing the shells in the lower layers.

Snails, whether for household consumption or for the market, can be stored safely for up to 6-8 weeks in a box or crate, if you do not want to collect them daily. First put a 5 cm layer of sawdust or finely cut corncob leaves on the bottom of the box; place over this a layer of snails, then another 3 cm layer of sawdust, and so on, ending with a covering layer. The box should be kept in a cool, shaded place, well protected from predators and poachers.

Snails can be transported to the market in baskets, boxes or sacks, but always take care not to damage them by putting too many together or on top of each other (max. 10 kg).

## Processing

Freshly gathered snails have just eaten (except if collected when aestivating or hibernating). They can be used directly, but all faeces and dirt must be removed in the kitchen. It is easier and more hygienic to have them defecate before use. Store them in a basket or sack in a cool, shaded place without food for four days, to enable them to discharge all aliments in their intestinal tract. They are now ready for washing, boiling and dressing.

### *Washing*

Put snails in a bucket with water, adding some salt and a dash of vinegar. Lemon or lime juice can be used instead of vinegar. Soon, the snails will start to discharge their slime: a milky, whitish liquid. Throw away the water and repeat the washing procedure until the water remains clear.

### *Boiling*

After washing, put snails into boiling water, again adding some salt and vinegar, or lime or lemon juice, and boil thoroughly for at least 5 minutes. *Achatina fulica* (but possibly the other GALS species as well) is reported to be an intermediate vector of the Rat Lungworm and other diseases potentially lethal to humans. Improperly cooked *Achatina fulica* meat may act as a major source of human infection in places where it is commonly eaten by people, such as Taiwan. Thorough boiling is essential!

### *Dressing*

Extract the snail from its shell, draining off the body fluid or haemolymph (unless local recipes call for its use), remove the viscera (heart, stomach, kidney, liver, intestines) and cut off the head. The meat is now ready for boiling, stewing, frying or whatever cooking technique your local snail recipe book calls for.

## 8.2 Consumption

### Composition and nutritive value

The data provided below originate from Nigerian studies of the GALS species *Archachatina marginata*. It can only be assumed that the composition and nutritive value of the other two GALS species discussed in this Agrodok are more or less the same.

*Table 2: Approximate dressing percentage of Archachatina marginata*

<b>Total live weight of snail</b>	<b>100%</b>	
meat	c. 40%	(the edible foot of the snail)
shell	c. 30%	
viscera	c. 17%	
body fluid	c. 13%	(haemolymph)

*Table 3: Approximate carcass composition (including moisture)*

<b>crude protein</b>	<b>60-&gt;80%</b>	<b>depending on diet of the snails</b>
fat	1.3-1.7%	
ash	1.3-1.4%	

As far as protein is concerned, snail meat compares well with traditional sources of protein like chicken meat, pork or beef.

A Nigerian study on mineral composition of snail flesh showed that values of iron, magnesium, calcium, potassium and sodium were consistently high; while cobalt, lead and copper – indicators of dangerous pollution – were not detected. Snail meat complements the minor and trace elements required for proper growth and development in humans, so it is recommended for regular consumption.

### Palatability

In Ghana *Achatina achatina* is considered the most prized species for consumption, followed by *Archachatina marginata* and *Achatina fulica*, in order of preference.

Several sources mention *Achatina fulica* as being slightly inferior to the edible European snails because it is 'rubbery' and often 'swampy tasting'. However, when highly flavoured with garlic, chopped and stuffed into shells of the genuine escargot, most people eating the African snails are effectively deceived!

On the other hand, a French website offers tinned *Achatina fulica* 'escargot' (around 10 g/snail, including shells – possibly to make them resemble the real escargot). Taiwanese sites offer tinned *Achatina fulica* snails for sale in Taiwan and China. The species is also sold as a local food source in Seoul, Korea.

### **Some traditional recipes**

In Ghana snails are used to prepare a variety of dishes, including soups, sauces and kebab. The big snails (locally referred to as 'atope') are preferred for soups. These range in weight from 120 to 450 g. However, juvenile snails (referred to as 'nwawaa' in Ghana, weighing between 20 and 40 g) are preferred for sauces.

The meat is removed from the shell and the tubular appendages attached to the mantle are cut off. The meat is washed repeatedly to remove slimy substances and dirt. It is then put in a saucepan, with enough water to cover it, and boiled. The water is then drained and the meat is washed a second time in cold water. Snail kebabs are prepared from spiced, boiled or fried snails.

For preparing light soup (Ghana) and pepper soup (Nigeria), already cooked snail meat is added to a variety of meats (for example, beef, mutton or fish) and sliced onions, and then steamed for about 10-15 minutes. Water is added to the steamed meat and brought to the boil. A blended vegetable mixture (including peppers and tomatoes) and salt are added, and the mixture is cooked until it thickens slightly. The soup can be served with such foods as fufu, rice, kenkey (corn dough), yam and bread. Other soups, such as palm-nut soup, groundnut soup and cocoyam leaf soup (also known as 'green green' in Ghana), can be prepared similarly.

For preparing sauces, the snail meat is washed with lime to remove the slime. It is then seasoned with garlic, a stock cube, salt and other spices and boiled for about 20 minutes or fried in oil. Sliced onions, peppers, tomato puree and herbs are fried and stock is added. The sauce is allowed to simmer over a low heat until smooth and thickened, stirring constantly. The fried snail meat is added and cooked gently on a low heat. This can be served with such foods as rice, yam, potatoes, plantain and kenkey (corn dough).

#### *Grilled spiced snails in palm oil (Gbarnga, Liberia)*

Ingredients: 800 g snails, palm oil, 3 tablespoons lemon juice, 1 teaspoon chilli powder (or red pepper), parsley leaves.

Preparation time 10 minutes; cooking time 15 minutes.

Remove snails from their shell, thoroughly wash the cleaned meat\* - taking care it does not contain any sand – and put on a plate. Sprinkle snails with the lemon juice and leave to marinate for 10 minutes. Sprinkle snails with chilli powder (or pepper) and spiced salt. Wrap in aluminium foil and put in preheated oven of 160 °C for 15 minutes.

Put palm oil in a dish, add finely cut parsley and spiced salt. Serve snails with the oil.

#### *Fried snails in tomato-chilli sauce (Igbini, Nigeria)*

Ingredients: 800 g cleaned snails, 400 g tomatoes, 100 g onions, 3 tablespoons palm oil, 3 tablespoons lemon juice, 1 teaspoon chilli powder (or red pepper), parsley leaves.

Preparation time 10 minutes; cooking time 20 minutes.

Thoroughly clean the snails with lemon juice\* and put on a plate. Sprinkle with lemon juice and leave to marinate for a few minutes.

Peel onions and wash tomatoes.

Heat oil in a pan, add tomatoes and fry 5 minutes. Add onions, snails, chilli powder and spiced salt and fry 10 minutes. Add chopped parsley and fry 5 more minutes. Serve warm.

\* There are two ways to remove the snails' slime after shelling. Washing them with the water of fermented cassava is the 'traditional' manner. This removes the slime as well as any 'rubbery' or 'earthy' taste. The second, 'modern' way is washing with lemon juice.

## 9 Markets

### 9.1 Local markets

In the high-altitude forest areas of West Africa, particularly in Ghana, Nigeria and Côte d'Ivoire, snail meat forms a substantial part of the meat in the diet of the local people. Snails are gathered in the wild, packed into bags, wooden crates or baskets and transported to selling points along main roads or to urban centres.

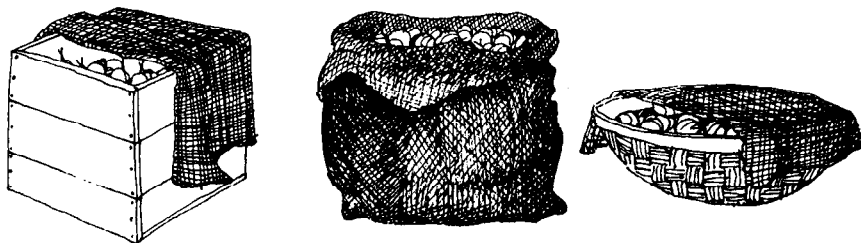

*Figure 23: Types of containers used to transport snails to markets*

The most common species sold at the roadside in West Africa are snails, duikers, brush-tailed porcupines, hares and grasscutters. Snails and grasscutters fetch the highest market prices per kilogram.

In urban areas, the gatherers may sell the snails directly to consumers or to wholesale traders or retailers. Snails can be smoked and stored for sale during the off season when prices are highest.

Snail price differences between the wet and dry seasons are vividly illustrated by the results of a snail marketing study carried out in Southern Nigeria (Eze *et al.*, 2006, see ‘Further Reading’), which are presented in table 4.

The channel of distribution for snails was from producers and hunters to retailers and then to consumers, or from hunters directly to consumers. Snail marketing was found to be marginally efficient in both the

wet and dry seasons, which may be attributable to problems such as the nature of the source of supply, poor storability and excessive price.

*Table 4: Nigerian snail prices in the wet and the dry seasons (1 US \$ = N127.50 in 2007)*

	Wet season	Dry season
Snail marketing gross return	N28,175	N43,680
Marketing costs	N25,940	N40,630
Net return	N 2,235	N 3,050
Marketing efficiency	1.09	1.08



*Figure 24: Woman selling snails*

A marketing study in South Benin (Sodjinou *et al.*) showed GALS marketing to be dominated by women. The marketing network comprised hunter-gatherers, wholesalers, and dealers. Gross margin was



relatively low for wholesalers, higher for market salesmen and high for gatherers, which encourages snail gathering in the wild and thus may lead to the snails' extinction. For that reason it is essential to get GALS-raising programmes off the ground.

Snails may take up to two years to reach the size that meets local consumer preferences. The marketable size required for export is slightly smaller.

In some areas of West Africa, snail meat has never been part of the local diet. In the predominantly Muslim northern areas of West Africa, snail meat is not consumed, for religious and cultural reasons.

### **Snail products**

A Nigerian study showed the feasibility of using **snail meal** of the giant African snail *Archatina marginata* as a partial fishmeal substitute in raising fish (*Clarias gariepinus*) (Oyelese, 2007), with a 60% snail meal/40% fishmeal mixture giving optimum results. The study puts the production cost of snail meal (oven-dried flesh including viscera) at N 250/kg versus N300/kg for fishmeal (1 US \$ = N127.50 in 2007). Production costs of snail meal might be further reduced by promoting the active rearing and marketing of the species for its values as a fishmeal product, and supplier of protein and nutrients for humans.

Underdeveloped or damaged snails may be fed to pigs.

**Shells** are often cited as a potential additional source of income from snail breeding, more specifically their sale to souvenir shops. This is obviously a very limited market and it would be unwise to base profitability calculations of your snail farm on a niche market like snail shells as adornments or souvenirs.

Crushed snail shells may be applied in chicken feed or in liming to improve the quality of acidic (fish pond) soils. However, do not forget that your snail feed must contain enough calcium to enable the snails to develop sturdy shells.

## Processed snail meat

Fresh snail meat can be processed, for storage or marketing, in several ways:

- At farm level, it can be smoke-dried for sale in the off season when prices are traditionally higher.
- Snail meat can be frozen or canned, for sale to domestic or export markets. This type of processing requires investments on a scale that is (probably) beyond the means of the individual snail farmer, though it might be undertaken by strong, prosperous farmers' cooperatives.
- On-farm processing of snail meat into locally well-received, tasty dishes, for sale at your own roadside shop or to nearby restaurants, may be another way of adding value to snail farm products. Obviously, you should abide by local sanitary regulations when starting and running a snail meal kitchen.

## 9.2 Export markets

France plays a central role in the growing international trade in snails. Some of the snails imported into France are processed and exported to other European countries or to North America, especially to the USA, which imports hundreds of millions of US dollars' worth of snail meat annually. Other important markets are Germany, Belgium, Netherlands, Canada, Switzerland, Japan, Sweden, Austria, Denmark and South Africa.

Among the major suppliers to these markets are Greece, Turkey, Rumania, Algeria, Tunisia, as well as Taiwan, Thailand and China. Most countries supply the European snail species *Helix aspersa*, *H. pomatia* and *H. lucorum*, while the Asian countries supply *Achatina fulica*. The snails are supplied fresh, frozen or canned. The African species fetch about one third of the price of the European species. This is mainly because, compared to the European species, the meat of the African species is considered to be rather rubbery and the shell less suitable for presenting the final product. European consumers generally prefer snails served in the shell.

However, studies by the Ministry of Agriculture, Fisheries and Food in the United Kingdom have shown that juvenile *A. achatina* snails are meatier and more tender than the more favoured European species. It is hoped that this finding will increase demand for the African species. For West African producers, this might mean not only a bigger market for their product but also reduced costs of production because of the shorter growing period required (for the snails to reach the size preferred by consumers). However, it will take some time before the long-standing prejudices in continental Europe against the African snail species are overcome.

Export markets clearly offer opportunities, though the small-scale snail producer should not underestimate the difficulties, including import regulations, hygienic and health requirements. It would seem that the small, local snail farmer might participate in export opportunities best through farmers' cooperatives, or by contract farming for large, local snail processing and export ventures.

# Appendix 1: Planning a snail farming venture - 5 steps

Step 1: Plan

- market
- production
- organisation

Step 2: Pilot production and sales, leading to:

Step 3: 'Go or no go decision'

Step 4: Investment in facilities and know-how

Step 5: Upscaling

- logistical control
- quality control
- financial control

## Step 1: Plan

*Marketing plan: why do you want to farm snails?*

- Own consumption
- Selling live snails to local market(s), local restaurants
- Selling preserved (frozen, canned) snail meat on distant markets

(Note: this Agrodok is not primarily intended for the snail grower for distant markets.)

*Production plan:*

Type of farming

*Part life cycle farming:* young snails collected from the wild, bought from other breeders or agricultural institutes, then raised on the farm to table size.

*Complete life cycle farming:* snails born and bred on the farm.

(Note: complete life cycle farming is recommended, to prevent diseases from being introduced into your farm by snails from outside).

*Farm size:* the size of your pilot snail farm will depend on your marketing plan. Nigerian experiments show optimal stocking density for

the giant African snails to be 100 snails/ m<sup>2</sup> for juveniles of 0.5-49 g, and 30/m<sup>2</sup> for pre-adults of 50-100g. Optimum density for breeding (egg-laying) snails is much lower: 6-7/ m<sup>2</sup>.

(Note: snail weight refers to the live snail, including the shell).

### *Species*

This manual concentrates on GALS, giant African land snails: *Achatina achatina* (coastal West Africa), *Archachatina marginata* (Central African rainforest zone), and *Achatina fulica* (originally from East Africa, now widely dispersed throughout the world). Using the local species for farming is obviously preferable, keeping in mind that – at least in Ghana – *A. achatina* is considered the tastiest species for consumption, followed by *Arch. marginata*, and *A. fulica*, in order of preference.

### *Organisation plan:*

- Family operation
- Commercial venture, financially and organisationally separated from your farm.

### **Step 2: Pilot production**

During the pilot production phase you should keep detailed records on which to base your go or no go decision to continue snail farming or stop.

- records of inputs: labour (your own or household members, hired labour), money, materials, feed and so on
- records of growth performance of your snails.

### **Step 3: Go or no go decision**

Only after carefully balancing *production costs* (per marketable snail, or per kg live snail, or dressed snail meat) and *sales revenue* will you be able to start a snail growing venture safely.

#### **Step 4: Investment in facilities and know-how**

Facilities:

- Location, type and size of cages or pens, depending on the scale of snail farming planned.
- Finance, corresponding to the scale of the snail farming operation:
- Private or family capital, micro-credit (Grameen Bank model) or commercial credit.

Know-how:

- Acquiring or improving your knowledge of snail farming through exchange of information, reading, attending courses, etc.

#### **Step 5: Upscaling**

- Logistical control: careful recording and control of inputs (labour, materials, feed and medicines).
- Quality control: growing and delivering healthy products (snails in this case).
- Financial control: careful recording and control of inputs, output, and profits.

**Note:** Points of attention under Step 5 apply to any farming operation.

## Appendix 2: Costs of constructing snaileries

Because of inflation, prices are meaningless and have been omitted. Complete the cost calculations by entering the local prices of construction materials and labour. Construction costs must include the cost of any transportation charges!

*Table 5: Hutch box (single chamber; 60 × 60 × 30 cm; suitable for 3-5 adult snails)*

Item	Description	Quantity	Price
1	5 × 7 × 488 cm timber (iroko)* (stilts)	1	
2	2.5 × 30 × 366 cm wooden board (box)	2	
3	Nylon mesh	0.45 m	
4	Wire net	0.45 m	
5	Nails (2.5 and 7.5 cm)	0.5 kg	
6	8 cm hinges, padlock	2, 1	
7	Labour	1 person-day	
Total			

\* Iroko is the trade name for odum wood

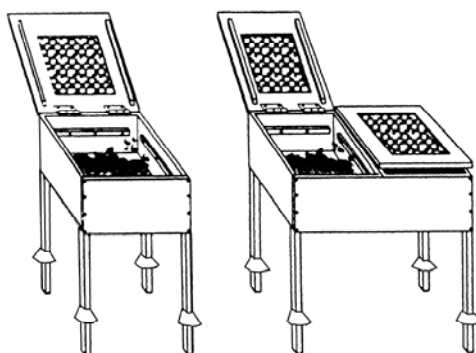
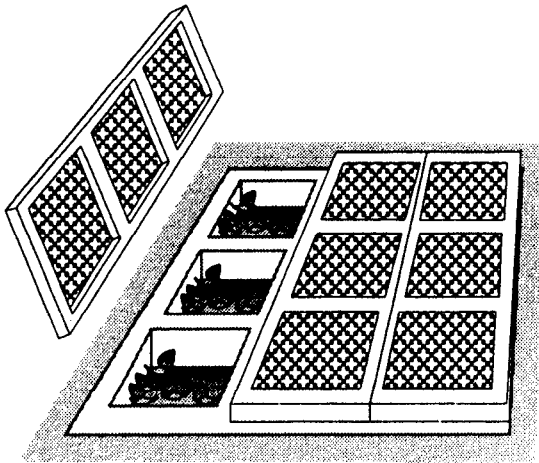

*Figure 25: Hutch box (single and double chamber)*

To build a double chamber hutch box, double the quantities of items 2, 3, 4, 5 and 6. Item 1 should be replaced by 5 × 10 × 488 cm timber.

*Table 6: Trench pen (set of 9 pens of 90 × 90 × 50 cm; each suitable for 10-15 adult snails)*

Item	Description	Quantity	Price
1	Sandcrete blocks 46 × 23 × 15 cm	96	
2	Cement	2 bags	
3	Nylon mesh	11 m	
4	2.5 × 5 × 330 cm timber (iroko)	10	
5	Nails (5 cm)	1 kg	
6	Labour (digging and laying blocks)	4 person-days	
7	Labour (making cover)	2 person-day	
Total			

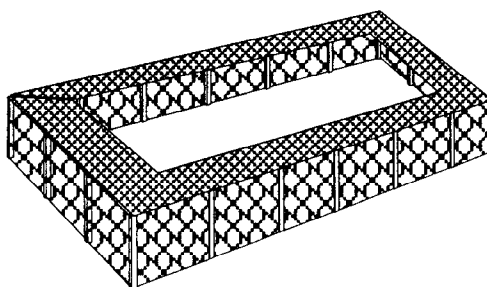

*Figure 26: Trench pen*



*Table 7: Mini-paddock pen (6 × 1.5 × 0.5 m; suitable for more than 200 adult snails)*

Item	Description	Quantity	Price
1	Nylon mesh	18 m	
2	5 × 5 × 366 cm timber (iroko)	3	
3	Nails (4 cm)	0.75 kg	
4	Nails (1.5 cm)	0.5 kg	
5	Labour	2 person-days	
Total			



*Figure 27: Mini-paddock pen*

The costs of a mini-paddock pen built with bamboo depend on the source of the bamboo and the transportation charges.

# Further reading

Akinbile S.M., 1999 (1<sup>st</sup> publ.) **Snail Rearing**. Erodise Business Networks, Ibadan, Nigeria. A simple booklet on giant African land snail farming.

Akinusi O., 1998. **Practical rational snail breeding**. In: Nigerian Journal of animal production 1998 (vol. 25, p. 1-2 & 193-197).

CADEV (Community Action for Development), 2006. **Snail farming as a source of employment**.

See: [www.postnewsline.com/2006/09/snail-farming](http://www.postnewsline.com/2006/09/snail-farming)

CADEV, 2006. **From a taboo to a delicacy: the evolution of eating snail meat in Bakossi (Cameroon)**. Non-wood News no. 15. FAO.

Cheney, S. and Thompson, R. Revised 2006. **Raising Snails**. Special Reference Briefs (National Agricultural Library SRB 96-05. Updates SRB 88-04). Beltsville, Maryland, USA: United States Department of Agriculture (USDA). This report on snail raising is derived from a review of the literature and searches of selected databases. Available online: [www.nal.usda.gov/afsic/AFSIC\\_pubs/srb96-05.htm](http://www.nal.usda.gov/afsic/AFSIC_pubs/srb96-05.htm)

Duah, O.A. and K.A. Monney (Dept. of Zoology, University of Cape Coast, Ghana), 2001. **Snail farming: Snail collection and small-scale production in Africa and Europe**. In: African Journal of Ecology, Vol.37 (3).

Eze, C.C., D.O. Ohajianya and N.N.O. Oguoma (Dept. of Agricultural Economics, Fed. Univ. of Technology, PMB 1526, Owerri, Nigeria) 2006. **Analysis of land snail marketing in Owerri agricultural zone of Imo State, Nigeria**. In: Animal Production Research Advances 2 (2): 94-99, 2006 E-mail Dr. C.C. Eze: [chriseze@yahoo.com](mailto:chriseze@yahoo.com)

Food and Agriculture Organization of the United Nations (FAO). 1986. **Better Farming Series: Farming Snails**. Economic and Social Development Series Nos. 33 and 34. Rome, Italy.

**Journal of Molluscan Studies**. Published three times a year in the United Kingdom, this journal includes articles on research on molluscs and related organisms.

Dr. Joseph R. Cobbinah, 1993. **Snail Farming in West Africa: A Practical Guide**. ISBN 9789290811022, 56 pages

Mariska Leeftang, Januari 2005. **Snail Farming**. AgroBrief-Series No 3, 6 pages, Agromisa, Netherlands.

Monney K.A., 1994. **Notable notes on giant African snails**. In: Snail Farming Research, Vol 5, p. 1-13.

Monney, K.A., 1998. **Prospects for snail farming in West Africa**. In: Tropical Science Vol. 38 (4, p. 238-247). E-mail: [infoclient@inist.fr](mailto:infoclient@inist.fr)

Okpeze, C.N. *et al.*, 2007. **Effects of feeding on adult snails**. In: African Journal of Biotechnology, Vol. 6(16).

Omole, A.J., A.A.Taiwo. and J.A. Amusan, 2007. **Practical Snail Farming**. Institute of Agricultural Research and Training (IAR&T), Obefemi Awolowo University, Ibadan, Nigeria.

Sheldon, C. 1988. **Raising Snails**. Special Reference Briefs (National Agricultural Library SRB 88-04). Beltsville, Maryland, USA: United States Department of Agriculture (USDA). This report on snail raising is derived from a review of the literature and searches of selected databases.

# Useful addresses

## **Alternative Farming Systems Information Center**

National Agricultural Library, U.S. Department of Agriculture  
10301 Baltimore Avenue, Room 132, Beltsville, MD 20705

W: <http://afsic.nal.usda.gov>

## **Erodise Business Networks**

101, BIMSNET building, opposite Oju-Odo Bus Stop,  
Iwo Road, Ibadan, Oyo State, Nigeria. T: - +234-702-589-5061

E: [info@erodise.com](mailto:info@erodise.com) , [erodise@consultant.com](mailto:erodise@consultant.com)

Publisher of “**Snail Rearing**”, by Stephen Akinbile (1999), and local Agrodox distributor.

## **ILEIA**

ILEIA, the Centre for Information on Low External Input and Sustainable Agriculture promotes exchange of information for small scale farmers in the South through identifying promising technologies involving no or only marginal external inputs, but building on local knowledge and traditional technologies and the involvement of the farmers themselves in development. Information about these technologies is exchanged mainly through the LEISA Magazine. All articles accessible on-line.

Contact: ILEIA, Zuidsingel 16, 3811 HA Amersfoort, The Netherlands  
T: +31(0)33-4673870, F: +31(0)33-4632410

E: [ileia@ileia.nl](mailto:ileia@ileia.nl), W: [www.leisa.info](http://www.leisa.info)

## **Practical Action (former Intermediate Technology Development Group (ITDG))**

ITDG helps people to use technology in the fight against poverty. Keywords are: ‘practical answers to poverty, sustainable solutions and people focused’. Addresses of offices can be found at the website:

[www.practicalaction.org](http://www.practicalaction.org)

# Glossary

<i>aestivation</i>	the state of dormancy during the dry season (warm season)
<i>agglutination</i>	the state of being clumped together, as if glued
<i>aphrodisiac</i>	a substance (food or drug) that stimulates sexual desire
<i>clutch</i>	number of eggs produced or incubated at the same time
<i>cold-blooded</i>	having a body temperature that varies according to the external climate
<i>deforestation</i>	the act of cutting down or clearing trees from a forest
<i>ecotype</i>	a population of any species of plant or animal with inherited characteristics that enable it to survive in a particular habitat
<i>ectoparasite</i>	a parasite that lives externally on its host
<i>extensive farming</i>	a farming system (always outdoors) in which the natural elements (plants, soils, weather, etc) play a dominant role, requiring minimal financial input
<i>feeding stimulant</i>	a food component that induces feeding
<i>haemolymph</i>	the snail's body fluid
<i>heliculture</i>	a system of raising snails in enclosures, indoors or outdoors (derived from <i>Helix</i> , the genus to which many species of European origin belong)
<i>hermaphrodite</i>	an organism which has both male and female reproductive organs
<i>hibernation</i>	the state of dormancy during cold periods
<i>humidity</i>	dampness, particularly of the air
<i>incubation period</i>	time between the laying and hatching of eggs

<i>intensive farming</i>	a farming system (indoor or outdoor) in a highly controlled environment, requiring high capital input
<i>mollusc</i>	an invertebrate animal which usually has a shell
<i>mortality</i>	frequency of deaths in proportion to population
<i>parasite</i>	an organism (usually small) that grows, feeds and is sheltered on or in a particular organism (its host) but contributes nothing to its host's survival
<i>pesticide</i>	a chemical used to kill pests of animals or plants
<i>predator</i>	an animal that preys on other animals
<i>putrefy</i>	decay or decompose with a fetid (foul) smell
<i>secondary parasite</i>	a parasite that lives on a host weakened by another organism or by unfavourable environmental conditions
<i>snailery</i>	enclosure or pen in which snails are reared
<i>tentacles</i>	a retractable structure in animals, bearing sense receptors and used to obtain food
<i>viscera</i>	the soft, internal organs of the body